

Clean Up Your  
**World**

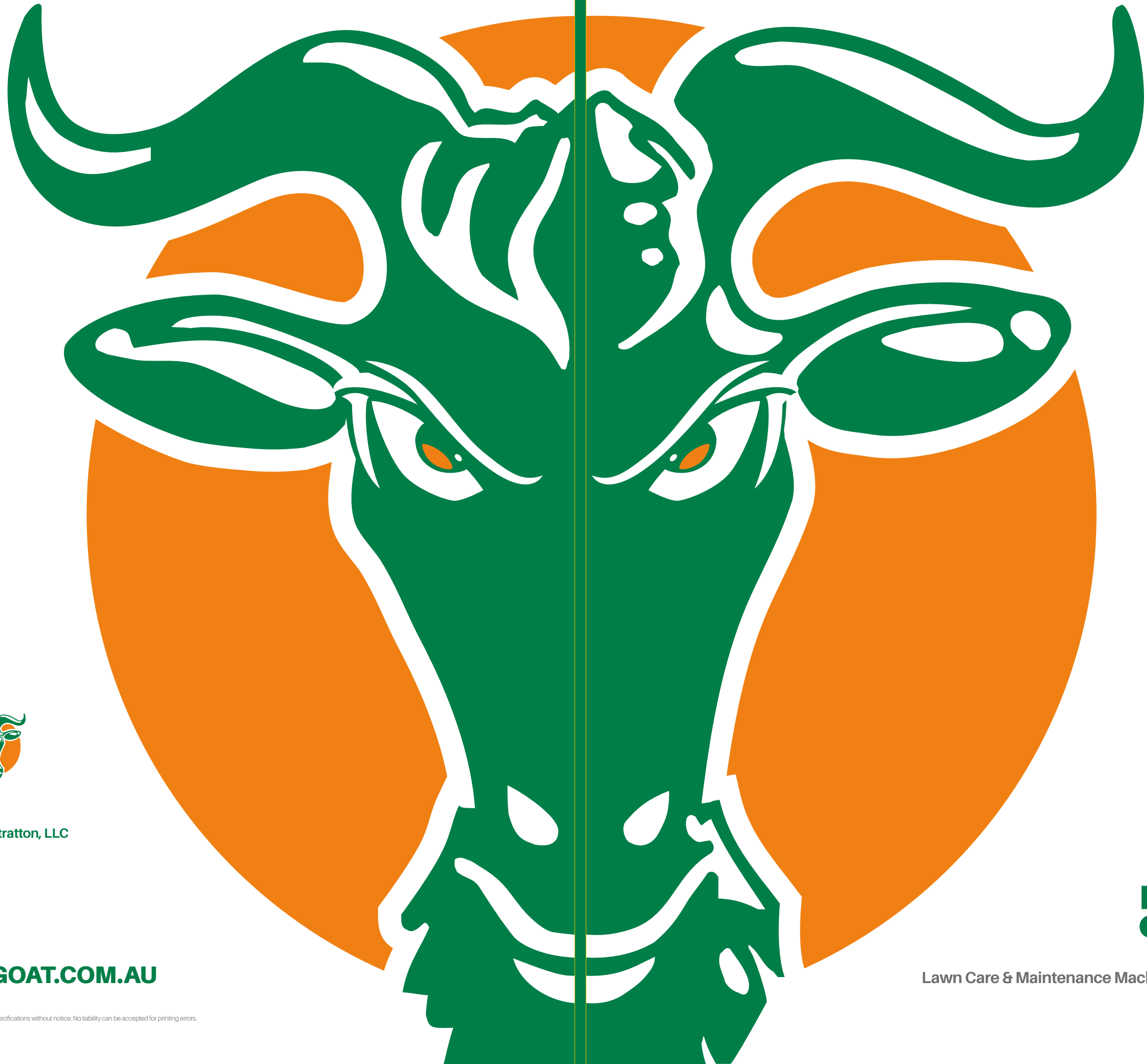

**Billy Goat® Industries**  
A subsidiary of Briggs & Stratton, LLC

Locked Bag 5004,  
St Clair NSW 2759  
P: 1800 356 632

**WWW.BILLYGOAT.COM.AU**



Lawn Care & Maintenance Machinery - **Catalogue 2026**

Briggs & Stratton, LLC. Copyright © 2026.  
We reserve the right to discontinue models or change specifications without notice. No liability can be accepted for printing errors.  
MK25216A



## Clean up your World™ with Billy Goat!

Thank you for your interest in Billy Goat! For more than 50 years, Billy Goat® has been the leader in making properties across the globe look fantastic. The equipment in this catalogue represents the best in specialty turf products with close attention to detail in an effort to make Billy Goat products simple to operate, highly productive, less fatiguing, and a pleasure to use!

Inside you will find innovative features like advanced fan technology in our blowers; hydrostatic drive systems and intuitive controls in our brush cutters, aerators, and turf cutters that take the guesswork out of ground speed and direction; customer-friendly ergonomics that reduce noise, weight, dust and vibration across the line.

Rest assured that Billy Goat products are customer focused, engineered and rigorously field tested to our customer's highest requirements which is why they are known for their outstanding durability and rugged performance year after year.

When it comes to cleaning up, Billy Goat features leading solutions for all your residential, commercial, and municipal cleanup needs. We invite you to review our range, refer to our website, watch our videos and work with our worldwide network of stocking and servicing dealers to pick the machine that is right for your cleanup needs.

Yours sincerely,  
Billy Goat Industries.



### Ground Care



Introduction	04
Power Rake	06
Aerators	08
Turf Cutter	12



### Cutting & Mowing



Introduction	14
Brushcutters	16



### Debris Management



Introduction	20
Force Blowers	22
Leaf & Litter Vacuums	25
Debris Loaders	32





# Turf and renovation projects for the perfect property

Keep your lawn in perfect condition with Billy Goat turf and renovation machines. With our powerful power rake you can remove thatch from turf the fast way. Our aerators let air in by the roots. Get to know our turf cutter for the easiest way to remove turf for your renovation projects or installation of pipework for irrigation in your lawn.

All the machines are made for durability and efficient working. They are very easy to operate making the whole range ideal for residential, professional users and hire companies.





Heavy duty and convertible to an overseeder

**PR Series**

PR551V

The PR Series efficiently removes matted thatch from turf in 20" / 51 cm passes, and its rugged design withstands the most demanding use. The rotation of the flail blade shaft is clock wise, this propels the PR forward, making it self propelled.

As the PR Series weighs slightly more than other power rakes on the market, with steel guards, heavier wheels, premium bearings, and a 3.6 mm steel engine base, the PR absorbs much of the vibration before it is transferred to the handle, which improves operator comfort and handling.

The PR comes standard with Vanguard® power coupled to a free swinging , heat treated, tempered flail blade reel, mounted to heavy-duty cast iron pillow block bearings with grease fittings.

The PR is convertible to an overseeder or vertislicer with optional accessories.

**Features**

**PR Series**



**Heavy Duty Depth Adjustment**  
Save on blade wear when compared to pre set adjustments that may promote premature flail wear. + 12mm to - 25mm.



**PR Flail Reel**  
Heat treated and tempered blades stand up to heavy use.



**Foldable Handles**  
Great for storage, transport and longer life.



**Premium Construction**  
Steel pulleys, easy to adjust idler and easy to change belt contribute to long life. Protected by a steel guard.

**Accessories**



**Vertislicing Reel**  
Perfect for thinning running grasses, improving drainage and overseeding. (350113)



**Overseeder Conversion Kit**  
Convert your Power Rake to an Overseeder. (350328)

USE / LEVEL	PROFESSIONAL / COMMERCIAL
	<b>PR Series</b>
	PR551V
ENGINE	
Engine Make	Briggs & Stratton
Engine Model	Vanguard 160
Performance kW (HP)	3.7 (5.0)
Displacement (cc)	169
POWER RAKE	
Productivity (m <sup>2</sup> /h)	1,225
Rake Width (cm/inch)	51 / 20"
Drive Type	Push
Rake depth (cm)	0.3 - 1.3
DIMENSIONS / WEIGHT	
Weight (kg)	73
Length x Width x Height (cm)	116 x 67 x 119
ACCESSORIES	
PR Vertislicing Reel (350113)	•
Flail Blade Kit (350186)	•
Overseeder Conversion Kit (350328)	•

\* All power levels are stated per SAE J1940 as rated by Briggs & Stratton.



Compact, easy to use drum aerator

Ideal for hire companies

**AE403 Drum Series**

AE403V

This mechanical 19" / 48cm wide aerator eliminates cumbersome filling of a conventional centre drum found on other units on the market, which are prone to wear, vibration and damage.

Billy Goat's outboard drive wheels also eliminate centre wheel slip and abuse from ramp loading with the tines engaged. Instead of bulky steel weights, water weight is positioned directly over the tines for better aeration depth.

Operators love the softest drive and tine engagement and the exclusive Lift N Lock™ feature allows the tines to be raised by simply lifting up on the handle.

The Fold-n-Go™ handles and the tilt up serviceability make service and transport convenient and simple.

The AE403V is powered by a Vanguard 169cc engine and can aerate up to 2,000m<sup>2</sup> per hour.



**The Benefits of Aeration**

The purpose of aeration is to create better conditions for the exchange of air and water in the soil, improving the penetration of water and fertilisers in the soil.

If turf is trampled and walked over continuously, the lawn develops a compact surface that leads to degradation of the lawn surface.



**Features**



**Outboard Drive Wheels**

Eliminate both centre wheel slip and abuse from ramp loading with the tines engaged.



**Single Bolt Tine Fastener**

Rock solid and easy to service.



**Tine Engagement and Lift N Lock™ Disengagement**

For best in class comfort and productivity.



**Water Tank**

Proprietary water tank eliminates bulky side weights. 23 litre capacity.

**Easy to Store and Service**

Tilt up serviceability plus Fold-n-Go™ handles are excellent for transport and storage and fold without tools.

**Accessories**



**Solid Steel Tines**

Excellent for improving drainage or for other no-plug applications. Single tine - 27381151 Pack of 4 - 360394-S Pack of 8 - 362611





**Cam-driven aerator**



**PLUGR®18**

PL1803V

This compact 18" (46 cm) aerator is ideal for smaller property aeration or hire companies and features reciprocating cam tines that propel the unit forward and drive cores up to 7 cm deep. The unit can aerate up to 2,000 m<sup>2</sup> per hour, is simple to operate for homeowners, easy to steer without lifting and requires no add-on weights.

The easy folding handle allows for compact transport and storage. Only four tines and no chains along with a no-tool removable cover make for easy maintenance.

This PL1803V model is powered by a reliable Vanguard® engine.

**Features**

**PL 18 Series**



**Easy Fold Handles**  
Folding handles provide compact transport and storage.



**ISO Mounted Handle**  
ISO mounted folding handles help reduce vibration and offers fatigue free operation so you can complete more work in less time!



**Cam-Driven Aerators**  
Punches tine core depths to 7 cm even in hard soil conditions. Spring loaded rotor assist for aggressive forward motion of the tine rods.

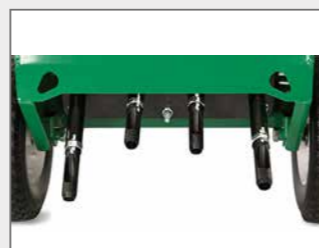

**Tensile Hardened Thin Wall Tines**  
Simple, durable screw-in design makes service simple. Four tines on PL18 Series.

TYPE	DRUM	RECIPROCATING CAM
	AE403 Series	PLUGR® 18 Series
	AE403V	PL1803V
<b>ENGINE</b>		
Engine Make	Briggs & Stratton	Briggs & Stratton
Engine Model	Vanguard 160	Vanguard 160
Performance kW (HP)	3.7 (5.0)	3.7 (5.0)
Displacement (cc)	169	169
<b>AERATOR</b>		
Productivity (m <sup>2</sup> /h)	2,000	2,000
Working Width (cm/inch)	48 / 19"	46 / 18"
Tine Type	Drum	Reciprocating Cam
Tine Depth (cm)	8.9	7
Number of Tines	24	4
Tine pattern (cm)	12 x 18	6.5 x 19
Drive Type	Self Propelled	Forward propulsion by tines
Transmission Type	One Gear	
Wheel Type	Semi-Pneumatic	Semi-Pneumatic
<b>DIMENSIONS / WEIGHT</b>		
Weight (kg)	110	109
Length (cm)	145	145
Width (cm)	74	61
Height (cm)	133	100

**Assorted Tine Sizes and Styles for PLUGR PL18 models**



\* All power levels are stated per SAE J1940 as rated by Briggs & Stratton.



Hydrostatic transmission



**SC18 Series**  
SC181H

The SC18 Series sod cutter is built upon the most rugged foundation in the industry with a superstructure frame featuring 23 kg of steel and supports a robust drive and cut system. A variable speed hydrostatic transmission allows operators to match cutting speed to ground condition in both forward and reverse.

The SC181H comes standard with a rear caster wheel for curved cuts and locks for straight cutting and handle isolation mounts absorb vibration for smooth, fatigue-free operation. Other user-friendly features include an hour meter, heavy-duty front bumper bar and six convenient tie-down points.

Coupled to Honda power with a 3-year warranty, Billy Goat's 18" / 46 cm hydro sod cutter will be a favourite for irrigation, landscape, hardscape, sports field, flatwork and golf customers.



**Features**



**Unique Paddle-Style Drive Wheels**  
SC181H model. For landscape applications. Designed to shed mud in wet conditions and grip in dry for improved cutting in all conditions.



**Tie Down Points**  
Convenient tie-downs make machine transport safe.



**Rear Swivel Caster**  
Perfect for curved work or making turns at the end of a pass. Locks for straight cutting.



**Vented Housing and Service Doors**  
Provides increased venting for cool operation. Three easy access service doors located at front / back of machine offer convenient access for servicing.



**Set and Forget™ Blade Depth Adjustment**  
Single lever and clamp at user's operating position adjusts simply, saving time and providing precise cutting depths to 6 cm.

USE / LEVEL	PROFESSIONAL / COMMERCIAL
	<b>SC18 Series</b>
	SC181H
<b>ENGINE</b>	
Engine Make	Honda
Engine Model	GXV160
Performance kW (HP)	4.1 (5.5)**
Displacement (cc)	163
<b>CUTTER</b>	
Cutting Width (cm/inch)	46 / 18"
Cutting Depth (cm)	6.3
Drive Type	Self Propelled
Transmission Type	Hydrostatic
Transmission Brand & Model	HydroGear RT310
<b>DIMENSIONS / WEIGHT</b>	
Weight (kg)	179
Length (cm)	152
Width (cm)	67
Height (cm)	98

\*\* All power levels are provided by Honda.





## Meadow and brush cutting the easy way

The Billy Goat walk behind range of brushcutters is made for cutting through overgrown bush, fields, clearing meadows or hiking trails. The combination of heavy duty fabricated mowing decks, with the heavy duty spindles and strong engines mean no job is too tough. The ergonomic controls make these brush cutters a perfect partner in some of the harshest environments.





Ideal for meadow work

**BC Series - Fixed Deck**

BC2600ICM

The 26" / 66 cm wide fixed deck commercial-duty brushcutter provides excellent stability in deep vegetation.

Propulsion is via a mechanical transaxle with 3 forward and 1 reverse gear. This arrangement is built to handle the toughest jobs, with no external gear linkages.

The heavy-duty blade spindle is reinforced on four sides to tackle the toughest cutting conditions, including thick brush, grass and weeds over 180 cm tall, and saplings up to 5 cm diameter. For operator comfort and high productivity, forward and reverse controls are at your fingertips.

This fixed deck brush cutter is powered by a trusted Briggs & Stratton I/C engine.

**Features**

**BC Series - Fixed Deck**



**Fixed Rear Discharging Deck**  
Does not articulate and pull, snag on hills, holes or uneven ground. Provides excellent stability in deep vegetation.  
Rigid Deck.

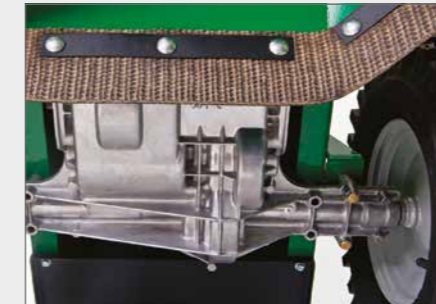

**Heavy-Duty Mechanical Transaxle**  
Combines the transmission and differential into one sealed package with no linkages to snag on brush.  
Three speeds and reverse.



**Ergonomically-Angled Control Handles with Padded Grips**  
Intuitive drive controls make it easier to move forward and reverse. Wide handles with padded grips and guards for maximum protection and leverage in deep brush.

**BC Series - Pivoting Deck**



**Pivoting Rear Discharging Deck**  
+/- 12 degree and 66 cm wide pivoting deck with proprietary return to neutral is engineered to glide over uneven terrain and deep brush.

BC2600ICH and BC2601HHC

**Wide Tyres**  
Wide Foam Filled Tyres for better traction and less down time.



**Heavy Duty Blade Spindle**  
Reinforced in four directions for maximum durability and safety, so you can keep cutting in the harshest conditions.



**Rubberised Rear Deck Trim**  
Allows for easier stump clearance in reverse.

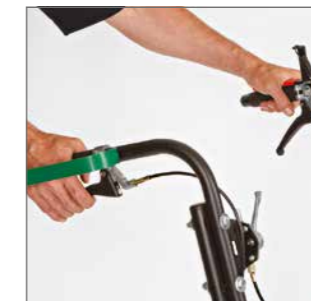

**Intuitive Drive Controls & Handles with Padded Grips**  
Best in class control package allows the user to feather in forward and reverse directly from the handles - no shifting required.



**Tuff Torq® Hydrostatic Transaxle**  
With ETC (Enhanced Traction Control) is fully automatic, sensing when the rear wheel starts to spin, locking the wheel to provides superior traction on hills or in wet and uneven conditions.



**Swivelling Front Caster Wheels (BC2601HHC)**

The swivelling caster wheels provide stability to the pivoting mower deck to cut brushes and weed evenly at higher heights up to 9,5 cm tall.

**BC Series - Pivoting Deck**

BC2600ICH  
BC2601HHC

The BC Series pivoting deck models offer all the great features of the fixed deck series models with the addition of a pivoting deck and variable Tuff Torq™ hydrostatic transmission with enhanced traction control.

Ergonomically angled handles with padded grips offer comfort and protection. Never take your hands off the machine to shift gears with conveniently located infinitely variable speed controls.

The BC2601HHC model introduces lockable front caster wheels for better hillside performance. The caster wheels also allow the brushcutter more mobility when being turned.

Your choice of a 344cc Briggs & Stratton Intek series engine on BC2600ICH, or Honda GXV390 power on BC2601HHC.



**Hydrostatic drive & swivel wheels.**  
Ideal for rough terrain, hills and high brush

Product shown:  
BC2601HHC

USE / LEVEL	ROUGH TERRAIN, HILLS & HIGH BRUSH		
	BC Series - Fixed Deck	BC Series - Pivoting Deck	BC Series - Swivel Wheels
	BC2600ICM	BC2600ICH	BC2601HHC

ENGINE			
Engine Make	Briggs & Stratton	Briggs & Stratton	Honda
Engine Model	Intek Series	Intek Series	GXV390
Performance kW (HP)	7.6 (10.3)*	7.6 (10.3)*	7.6 (10.2)†
Displacement (cc)	344	344	389
Starting	Recoil Start	Recoil Start	Recoil Start

BRUSHCUTTER			
Productivity (m²/h)	2,700	2,700	2,700
Cutting Width (cm/inch)	66 / 26"	66 / 26"	66 / 26"
Height of Cut (cm)	9.5	9.5	4.5 - 9.5
Height of Cut Adjustment	Fixed	Fixed	Adjustable
Drive Type	Self Propelled	Self Propelled	Self Propelled
Transmission Type	Gearred	Variable Hydrostatic	Variable Hydrostatic
Gears Forward	3	-	-
Gears Reverse	1	-	-
Diff Lock	-	Enhanced Traction Control	Enhanced Traction Control

DIMENSIONS / WEIGHT			
Weight (kg)	143	143	147
Length (cm)	183	183	203
Width (cm)	78	78	78
Height (cm)	121	121	121



\* All power levels are stated per SAE J1940 as rated by Briggs & Stratton. † All power levels are provided by Honda.



## Clean up with our vacuums, blowers and debris loaders

From small property residential to large property commercial leaf clean-up, Billy Goat's full line of Debris equipment gets your job done easy and fast. With the biggest range of vacuums you always find the best machine. The light Force™ blowers are up to 30% lighter and deliver up to 6.2 the power of a backpack. If you have to manage big amounts of leaves or rubbish, let us convince you by the power of our debris loaders. Check on the next pages which machine fits your job.





Productivity boosting performance on hard surfaces

Model shown: F902H



F1002 Air Volume - 3.8x backpacks\*

Professional use

Model shown: F1402SPV



F1402 Air Volume - 6.2x backpacks\*

**F10 Series**

F1002V

Step up to commercial clean up power. This unit is ideal for medium size maintenance contractors and large property owners.

**F14 Series**

F1402V

Professional power and productivity, the Vanguard powered force blower is a favourite for full size landscapers, schools, parks departments, cemeteries, resorts and golf and estate properties.

**Features**



**Aim N Shoot™**

Directs the airflow where you need it most with fingertip control and is lockable for single positions.



**Smooth, Rounded Housing**

Eliminates air voids for a smooth, quiet, powerful flow. Proven design won't rust or dent. Backed by a 5-Year housing warranty.

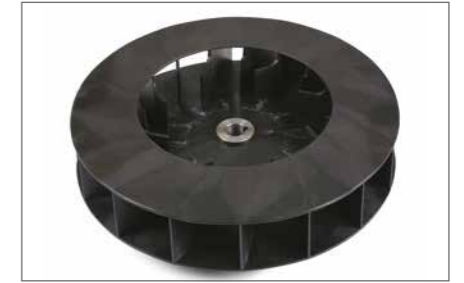

**Advanced Fan Technology**

Features a single shot 16-blade closed face fan, twice as many blades as others on the market.

**Accessories**



**Caster Wheel Kit**

Allows more manoeuvrability in tight spaces for moving airflow from side to side, without lifting the front wheel. (440293)



**Parking Brake Kit**

Locks drive wheels to park the force blower on hill sides. (440140)



**Quick Hold Down Kit**

Quick trailer lock down attachment saves time. (440120)



**Foam Filled Front Tyre**

Foam filled tyres cannot be punctured, avoiding costly downtime and tyre replacements. (440279)

**Key Features:**

- All models feature Aim & Shoot™ throwing debris farther
- 5 year housing warranty.

\* Relative to most large backpacks. In accordance with ANSI 175.2 standard.

USE / LEVEL	MEDIUM	LARGE
	<b>F10 Series</b>	<b>F14 Series</b>
	F1002V	F1402V
<b>ENGINE</b>		
Engine Make	Briggs & Stratton	Briggs & Stratton
Engine Model	Vanguard	Vanguard
Performance kW (HP)	7.5 (10.0)*	10.4 (14.0)*
Displacement (cc)	305	408
<b>PERFORMANCE</b>		
Output Diameter (cm)	10.2	12.7
Drive Type	Push	Push
Air Velocity (km/h)	320	320
Impeller Blades	16	16
Fan Size (inch (cm))	17 (43.2)	17 (43.2)
Front Wheel Tyres (inch (cm))	10 (25.4) x 3 (7.6)	10 (25.4) x 3 (7.6)
Front Tyre Type	Pneumatic	Pneumatic
Rear Wheel Tyres (inch (cm))	13 (33) x 5 (12.7)	13 (33) x 5 (12.7)
Rear Tyre Type	Pneumatic	Pneumatic
<b>DIMENSIONS / WEIGHT</b>		
Weight (kg)	65	71
Length (cm)	143	143
Width (cm)	74	72
Height (cm)	114	114
<b>ACCESSORIES</b>		
Caster Wheel Kit (440293)	•	•
Quick Hold Down Kit (440120)	•	•
Parking Brake Kit (440140)	•	•
Foam Filled Front Tyre (440279)	•	•

\* All power levels are stated per SAE J1940 as rated by Briggs & Stratton.

## Debris Management - Leaf & Litter Vacuums



Compact and easy to manoeuvre

### LB Series LB352

The Little Billy outdoor leaf and litter vacuum, weighing only 26 kg and 51cm / 20" wide, is a particularly light and manoeuvrable entry level vacuum featuring superior suction. The unit is ideal for vacuuming leaves, grass and garden debris on patios or hard surface areas. Powered by a reliable Briggs & Stratton 500E Series™ engine.



Easy operation

Model shown: KV601FB With optional hose kit

### KV Series KV601FB, KV601SPFB

Powerful suction and easy operation make clean up a snap for leaves, seeds, mulch, blooms, branches, litter and debris. Ideal for multi-surface residential and light commercial use, Billy Goat's versatile 69cm / 27" wide lawn and litter vacuum has variable height adjustment for hard surface or turf work. 30cm / 12" tyres on the push vacuums and rear wheel drive on the self propelled vacuums makes operation easy, even in hilly environments. The KV Series vacuums are powered by trusted Briggs & Stratton engines.

\* All power levels are stated per SAE J1940 as rated by Briggs & Stratton.



**KV Series Features**



**Robust Transmission**  
Single speed self propelled.  
Great for hilly turf applications.  
KV601SPFB only



**Integral Dust Skirt**  
Keeps dust down and away from  
the operator.

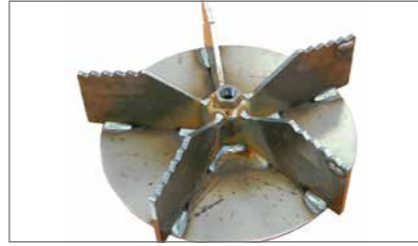

**5-Blade Serrated Impeller**  
Maximizes suction, long life time  
and debris reduction.

**Accessories**

**LB Series**



**LB Hose Kit**  
10 cm x 210 cm  
(900460)



**LB Turf Bag**  
Turf bag for Little Billy. 105 litre capacity.  
(900719)

**KV Series**



**Caster Wheel Kit**  
Increases manoeuvrability.  
(891128)



**Nozzle Wear Kit**  
Prevents nozzle wear on hard surface  
applications.  
(891127)



**Foldable Turf Bag**  
For increased airflow. 151 litre capacity.  
(891132)  
Also available zipper-free felt bag.  
(891126)

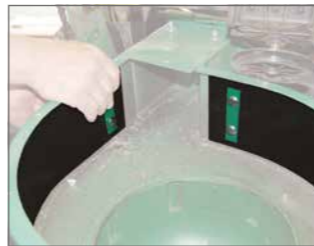

**Liner Sleeve**  
Protects housing in sandy conditions.  
(891134)



**Cover**  
Waterproof.  
(891137)



**KV601FB with Hose Kit**  
The optional hose kit helps  
between shrubs, beds  
and under decks or utilities.  
With telescopic handle  
(891125)

**MV Series**

MV601  
MV601SP

Step up to the heavy-duty clean up power of the MV Series 74cm/29" wide lawn and litter vacuums. Designed for both hard surfaces and turf, the MV Series is ideal for larger properties, commercial lots, leaf clean up, hire companies, parks, city streets, school districts or municipal clean up. Powerful 6-blade serrated impeller for maximum suction and debris reduction. Picks up cans, bottles, grass clippings, litter and other debris with ease. Abrasion-resistant composite housing components reduce weight and won't rust or dent.

The MV Series vacuums are available as a push only unit, or the convenience of a self propelled, 3 speed drive.



Model shown:  
MV601SPH with optional hose kit



Features



**74 cm / 29" Gobbler Door**  
Adjustable from the operator's position for easy switching between hard surface, turf or hose applications.



**Unique Top Fill Design**  
Keeps dust out of operator's face and ensures optimum filling.



**Top Loading Bag**  
Slides in and out on rails for best in class unloading. The 151 litre mesh bag holds up to 23 kg of debris.



**Easy Control of Height**  
Crank style for optimum performance on turf and hard surfaces.



**3-Speed Transmission**  
The MV601SP self propelled model is equipped with a 3 speed ultra smooth and durable transmission.



**36cm / 14" Wheels**  
The 14" wheels smooth out the rough areas and increase manoeuvrability.

Accessories



**Electrostatic DUST SOCK™ Kit**  
Traps dust for optimum operator and air quality protection. (27840263)



**Disposable Bag Liners**  
Eliminates the extra step of bagging your debris. Pack of 12. (840134 - 12 pack)



**MV Series Hose Kit**  
MV Series vacuum with optional hose kit attached to the gobbler door. With telescopic handle. Diameter 12.7 cm / 5". Length 305 cm / 10'. Model shown: MV601SPE. (840116)



**Cover**  
Waterproof. (891137)



**Caster Wheel Kit**  
Increases manoeuvrability. (27840129)



Model shown: QV550HSP with optional hose kit

Low dust, low noise with QuietVac™

**QV Series**  
QV550HSP

Billy Goat's 84cm / 33" QUIETVAC™ is the world's quietest vacuum. It's unique cyclonic filtration with exclusive Dust Sock™ technology that dramatically reduces dust in dry conditions.

The housing and 6-blade armour plate steel fan combination provide optimum suction power and 12 to 1 debris reduction for composting in dry conditions.

This hard surface machine is ideal for contractor use and municipal clean up applications such as tarmac, school campuses, hospitals, parks, churches, airport pedestrian areas, resorts, city streets and pavements, propelled vacuums, all powered by Honda.





Features



**QUIETVAC™**

As low as 97 LWa and 77 dBa at full rpm and 96 LWa and 76 dBa at 2800 rpm.



**Debris Bag Dust Skirt**

The QV Series vacuums are equipped with a debris bag dust skirt as standard fitment.



**Turf Bag**

Large 136 litre turf bag with 4 hooks. Loading and unloading is fast and easy.



**Powerful Suction**

Unique housing and fan system provides the best suction power of any vacuum on the market today.



**Durable Front Casters**

Roll smoothly through turns and over uneven surfaces.



**Easy Steering**

Thanks to the clutches on the handlebars the QV Series is easy to manoeuvre, even in the most restricted areas.



**Hydrostatic Drive Transmission**

Ground speeds from 0-3 mph (0 ~ 4.8 km/h) with infinite forward and reverse.

**Unique Cyclonic Filtration**  
The cyclonic filtration system, when combined with exclusive DUST SOCK™ technology, dramatically reduces dust in dry conditions, providing the ultimate in operator comfort.

**Electrostatic DUST SOCK™**  
The DUST SOCK™ acts as a secondary filter lowering the amount of dust that escapes the bag. It is used in dry and dusty conditions only.

Accessories



**Replacement Bag**

Replaces the original vacuum bag. 136 litre capacity. (831617)



**Collapsible Hose**

5' x 10' (12.7 x 305 cm) hose; hand extension for best in class ergonomic use; on board storage. (831018)



**Liner Sleeve**

Protects housing in sandy conditions. (831610)

USE / LEVEL	SMALL SIZE	LIGHT COMMERCIAL / RESIDENTIAL		PROFESSIONAL / COMMERCIAL		
	LB Series	KV Series		MV Series	QV Series	
	LB352 (883059)	KV601FB (883219)	KV601SPFB (2691989)	MV601 (2691991)	MV601SP (2691992)	QV550HSP (883069)
<b>ENGINE</b>						
Engine Make	Briggs & Stratton	Briggs & Stratton	Briggs & Stratton	Briggs & Stratton	Briggs & Stratton	Honda
Engine Model	500 Series™	Professional Series™	Professional Series™	Professional Series™	Professional Series™	GX160
Performance kW (HP)	2.6 (3.5)*	4.5 (6.0)*	4.5 (6.0)*	4.6(6.0)*	4.6(6.0)*	4.1(5.5)†
Displacement (cc)	140	190	190	190	190	160
Starting	Recoil Start	Recoil Start	Recoil Start	Recoil Start	Recoil Start	Recoil Start
<b>VACUUM</b>						
Productivity (m³/h)	1,260	2,900	2,900	4,250	4,250	2,850
Working Width (cm/inch)	51 / 20"	69 / 27"	69 / 27"	74 / 29"	74 / 29"	84 / 33"
Drive Type	Push	Push	Self Propelled	Push	Self Propelled 3-gear	Self Propelled
Transmission Type	-	-	-	-	-	Hydrostatic
Housing Material	Composite	Metal	Metal	Composite	Composite	Metal
Wheels (inch)	8"	12"	12"	14"	14"	13" / pneumatic
Impeller Blades	4	5	5	6	6	6
Impeller Type	Non serrated	Serrated	Serrated	Serrated	Serrated	Serrated
Bag System	Zipper Bag	Felt bag w/zipper	Felt bag w/zipper	Sliding Bag	Sliding Bag	Bag with 4 hooks
Bag Capacity (l)	105	151	151	151	151	136
<b>DIMENSIONS / WEIGHT</b>						
Weight (kg)	26	53	60	73	82	103
Length (cm)	119	158	158	163	163	160
Width (cm)	55	68	68	74	74	84
Height (cm)	102	110	110	116	116	130
<b>ACCESSORIES</b>						
Hose Kit	•	•	•	•	•	•
Caster Wheel Kit		•	•	•	•	
Nozzle Wear Kit		•	•			
Liner Sleeve		•	•	•	•	•
Cover		•	•	•	•	
Replacement Felt Bag		•	•			
Optional Felt bag w/marine clasps		•	•			
Replacement Mesh bag (Optional on KV models)		•	•	•	•	•
DUST SOCK™ Kit				•	•	Standard
Disposable Bag Liners				•	•	

\* All power levels are stated per SAE J1940 as rated by Briggs & Stratton. † All power levels are provided by Honda.



**DL14 Series**

DL1402VE

The new DL1402VE is a versatile debris loader, ideal for contractors, stables and mid-sized municipal applications. The heavy-duty DL1402VE offers an all-new discharge chute for rugged wear and long life productivity, and features a dual shredding 16" diameter armor plate impeller with Piranha™ blade that reduces debris up to 12:1. With standard electric start, the DL1402VE makes cleanup even easier.

The 25 cm intake hose is a 300 cm long, clear poly helical coil.



**DL18 Series**

DL1802VE

Step up to the midsize series of debris loaders, ideal for mid to large municipal and contractors applications. The DL18 Series heavy-duty debris loader is powered by a Vanguard™ engine, producing suction at 6,300 m³/h.

The DL18 Series debris loader features a 40 cm / 16" diameter armor plate steel impeller with 8 cutting points, replaceable poly liner and a 12-gauge (2.7 mm) steel housing for maximum suction power.

The debris loader can be mounted with the optional hanger kit or skid mounted to a truck or trailer bed.

The 25 cm intake hose is a 300 cm long, clear poly helical coil.

Dual Shredding and CustomFit™ mounting options are available on all Debris Loaders.

**High suction capacity**



Model shown: DL3701V

**DL37 Series**

DL3702VE

When commercial productivity counts, the DL37 debris loader is the most popular contractor and municipal machine.

The DL37's 37 HP Vanguard™ EFI engine delivers easier starting and fuel savings of up to 25% over carbureted equivalents. It is coupled to a 6-blade, armor plated impeller with 18 cutting points and dual shredding Piranha™ technology for up to 12:1 reduction and 8,580 m³/h of suction power. The 35 cm intake hose is 300 cm long.



**Vanguard™ EFI engine**  
By adding EFI, Vanguard™ engines deliver easier starting and fuel savings of up to 25% over carbureted equivalents. Available on DL37 Series debris loaders with 3 year warranty.





Features



**Dual Shredding System with Piranha™ Blade**  
For extra shredding. Serrated blades with cutting points for maximum loading. Debris reduction up to 12:1.



**Safety Kill Switch**  
Quick connect / release hose clamp with safety interlock.



**Urethane Clear Hose**  
Clear hose allows for visual inspection and quick removal of hose clogs. Replacement hoses are available.



**Intake Hose Storage**  
Simple secure nozzle hook for convenient and efficient storage.

CustomFit™ Mounting Options and Accessories



**Discharge Chute Deflector Kit**  
Deflects debris for most efficient loading (27812295).

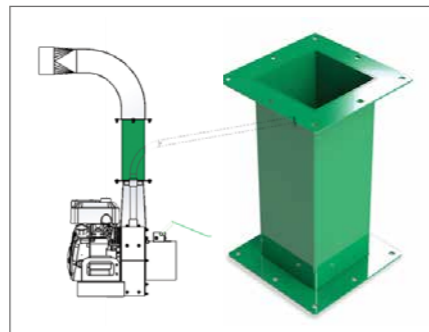

**CustomFit™ Extension Kit**  
Extends discharge height. Cannot be used with rotational kit. 40cm kit (812123-S) suits DL14, DL18. 30cm kit (792117-S) and 60cm kit (792119-S) suit DL37.



**CustomFit™ Receiver Hitch**  
Simple to install and remove and easily mounts to your truck for use with DL14 and DL18 loaders (27812601).



**Adjustable Rotating Discharge Chute**  
No tool, hand adjustable rotating discharge chute allows 360° positioning. Suits DL14, DL18 (813604) and DL37 (27793600).



**CustomFit™ Hanger Kit**  
Easy to install, locks in place with 2 bolts. Suits DL14 and DL18 loaders (27812260).

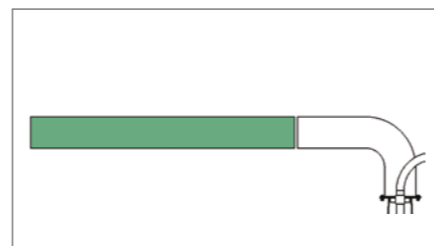

**CustomFit™ Discharge Hose Kit**  
Flexible hose kits to extend discharge by 150cm on DL14, DL18, and DL37 models for customisation to your truck or trailer. Urethane Kit (27812300) suits DL14 & DL18. Urethane Kit (27791107) & Metallic Kit (791106) suit DL37.

USE / LEVEL	MEDIUM		LARGE
	DL14 Series	DL18 Series	DL37 Series
	DL1402VE	DL1802VE	DL3702VE

ENGINE	DL14 Series	DL18 Series	DL37 Series
Engine Make	Briggs & Stratton	Briggs & Stratton	Briggs & Stratton
Engine Model	Vanguard™	Vanguard™	Vanguard™ EFI
Performance kW (HP)	10.4 (14.0)*	13.4 (18.0)*	27.6 (37.0)*
Displacement (cc)	479	570	993
Engine Features	Electric Start	Electric Start	Electric Start, Electronic Fuel Injection
Fuel Capacity (l)	6.5	8.5	22

LOADER	DL14 Series	DL18 Series	DL37 Series
Productivity (m³/h)	6,300	6,300	8,580
Hose Dimensions (cm)	25 x 300	25 x 300	35 x 250
Impeller Blades	4	4	6
Impeller Diameter (inch (cm))	16 (40)	16 (40)	20 (51)
Impeller Housing	Steel 12-gauge, Replaceable Liner	Steel 12-gauge, Replaceable Liner	Steel 12-gauge, Replaceable Liner
Cutting Points	8	8	18
Output Diameter (cm)	15	18	20

DIMENSIONS / WEIGHT	DL14 Series	DL18 Series	DL37 Series
Weight (kg)	124.28	127	215
Length (cm)	152	152	152
Width (cm)	82	82	82
Height (cm)	190	190	190

ACCESSORIES	DL14 Series	DL18 Series	DL37 Series
CustomFit™ Extension Kit	•	•	•
CustomFit™ Hanger Kit	•	•	•
CustomFit™ Swing Away Hitch	•	•	•
CustomFit™ Receiver Hitch	•	•	•
CustomFit™ Stake Body Swing Away Hitch	•	•	•
CustomFit™ Discharge Urethane Hose Kit	•	•	•
CustomFit™ Discharge Metal Hose Kit	•	•	•
Replacement Hose	•	•	•
Rotating Discharge Chute Kit	•	•	•
Discharge Chute Deflector Kit	•	•	•