

KV HOSE KIT P/N 891125



BILLY GOAT KV HOSE KIT (P/N 891125)

PURPOSE: To allow for vacuuming in hard to reach places.

INSTALLATION:

Step 1. Attach nozzle wear guards.

1. Disconnect spark plug wire.
2. Raise the nozzle height to its highest position and secure the unit from moving.
3. Remove the two bolts, nuts and washers on the sides of the nozzle that hold the reinforcement bracket on the interior of the nozzle. Do not discard the old hardware.
4. Slide the guards into place then secure the guards with the hardware previously removed.
5. Tighten the hardware using two 7/16" wrenches.
6. Repeat steps 2 through 5 on the left hand side.

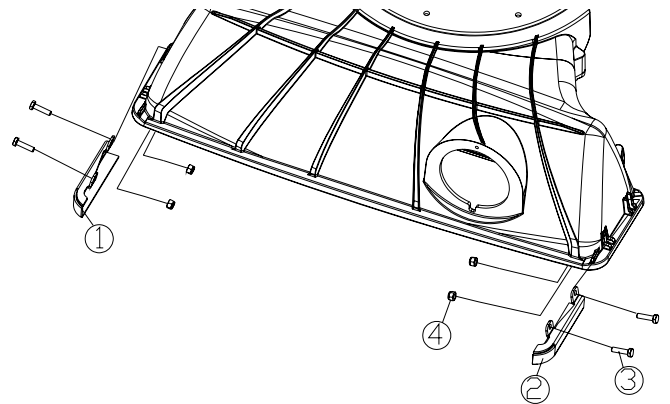

WARNING! Improper attachment of nozzle holder can cause damage to the hose from hot exhaust exiting the engine.

Step 2. Attach the hose nozzle bracket (item 10).

1. Remove the two screws on the **muffler side** of the top plate. Left side for Briggs and right side for Honda (see figure at right). Attach the bracket with the screws (item 12) provided. **Do Not** over tighten as this may strip the screws.

Briggs

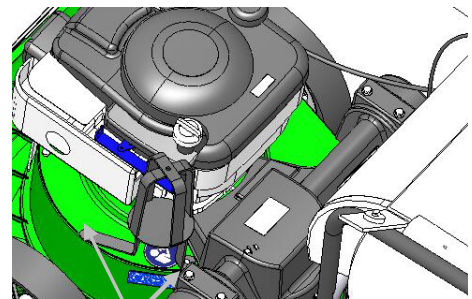

Remove the screws from these two positions

Honda

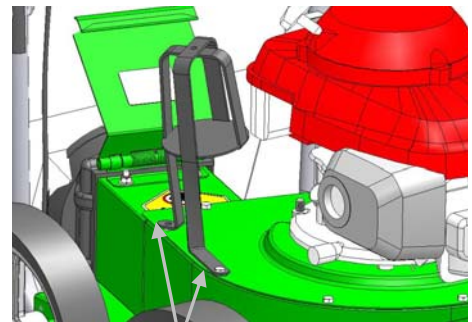

Remove the screws from these two positions

TKV

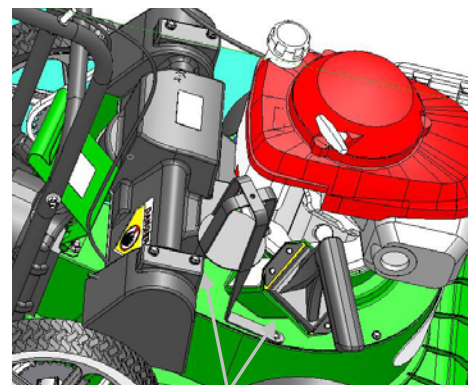

Remove the screws from these two positions

INSTALLATION: continued

Step 3. Attach coupler (item 8) and nozzle to hose.

1. Slide the two hose clamps over both ends of the hose and at one end attach the coupler to the hose using a 5/16" nut driver. **Note:** the hose is attached to the end of the coupler without the pin. Make sure the hose is completely seated next to the plate and secure it with one of the hose clamps. Next attach the nozzle with the handle to the other end of the hose by sliding it into the hose with enough distance to allow the clamp to hold the hose to the nozzle securely then tighten the clamp.

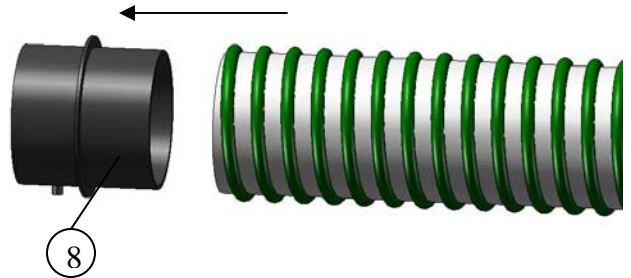
**Step 4. Attach the hose-holding bar (item 11).**

1. Connect loop on right side of wire bracket hose retainer to the upper handle of the machine, pull left side of wire until the loop will go over the upper handle.
2. Attach the blocker plate to the wire bracket hose retainer when not in use by sliding the wide slot over the top of the wire bracket and then sliding it down to its resting position.

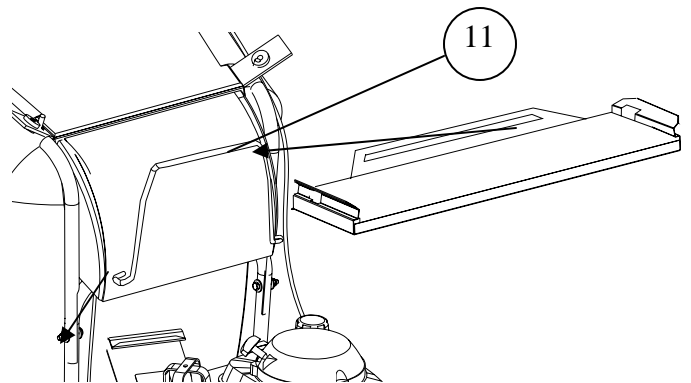
**Step 5. Attach hose coupler to nozzle housing.**

1. Slide the hose coupler into the nozzle housing. Slide it in at an angle and insert one of the pins into the slot, then rotate and slide the other pin through, this will allow the coupler to sit flush.
2. Reconnect spark plug.

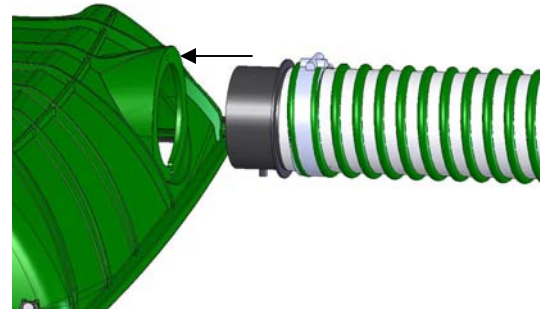
**Step 6. Hose placement when not in use.**

1. With the hose off to the left side of the machine (on the Honda model), drape the hose over the hose wire bracket holder and rest the nozzle into the nozzle bracket holder. **Note:** The hose should be wrapped around the right side of the machine with Briggs models. Use this method of transporting the hose when not in use (See picture right). **Warning:** Do not let the hose come into contact with hot parts of the engine, as this will damage your hose and is not covered by the warranty.





KV HOSE KIT P/N 891125

Operation

1. Simply slide the plate (item 10) onto the wear guards till the front is flush with the front edge of the nozzle. To remove simply apply pressure to the outside edges at the wear brackets and slide forward. This will allow suction through the hose when attached rather than the nozzle. To remove the plate push outward on the tabs and this will allow you to slide the plate off.

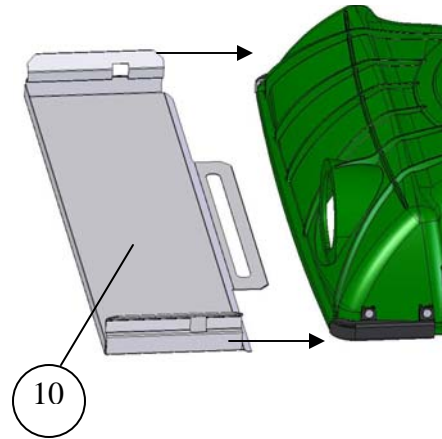

ITEM NO.	PART NUMBER	DESCRIPTION	QTY.
1	891029	NOZZLE GUARD RH	1
2	891031	NOZZLE GUARD LH	1
5	891044	HOSE 4" x 7' CLEAR PVC GREEN HELIX	1
6	800896	CLAMP HOSE 4"	2
7	800803	NOZZLE ASSY 4"	1
8	890040	HOSE COUPLER	1
9	891122	NOZZLE RETAINER BRACKET	1
10	891030	NOZZLE BLOCKING KV	1
11	890025	WIRE BRACKET HOSE RETAINER	1
12	891146	SCREWCAP 1/4-20 X 1" HWH TYPE F	2
Reference hardware			
3	8041006	SCREWCAP 1/4-20 X 1"	4
4	8160001	NUT LOCK 1/4-20	4





HOSE CARE & SHIPPING INFORMATION

SHIPPING TAG

IMPORTANT NOTICE

This merchandise was in perfect condition when packed and shipped.
Unpack immediately and check for damage.
Place any damage claim with delivering carrier and have inspection made at once.
Our warranty covers manufacturing defects only.
DO NOT RETURN TO SHIPPER.

SHIPPER-WARNING

TOP LOAD ONLY TO PREVENT SHIPPING DAMAGE.

HOSE CARE

ATTENTION!

- Hoses are wear items and are **only** warranted against manufactures defects. Hose must be inspected for shipping damage before using.
- Proper care is required to prevent damage. Operators should be cautious and keep the hose as straight as possible when vacuuming to not only help prevent clogging, but also to also help prevent abnormal wear to the sides of the hose. Rotate hose periodically to extend life. (Suggest ¼ turn every 20 hours.)
- Hose that has been exposed to extreme temperatures, chemicals, abrasive material or that have been run over will not be warranted.
- The 8" (810523), 10" (810705), and the 12" (790148) hoses have internal wrapping must be installed so the overlapping edges face in the direction of airflow. These hoses are marked by the manufacturer with an airflow direction arrow. Installing the hose with the airflow direction arrow reversed will cause premature failure and **VOIDS** the warranty.