

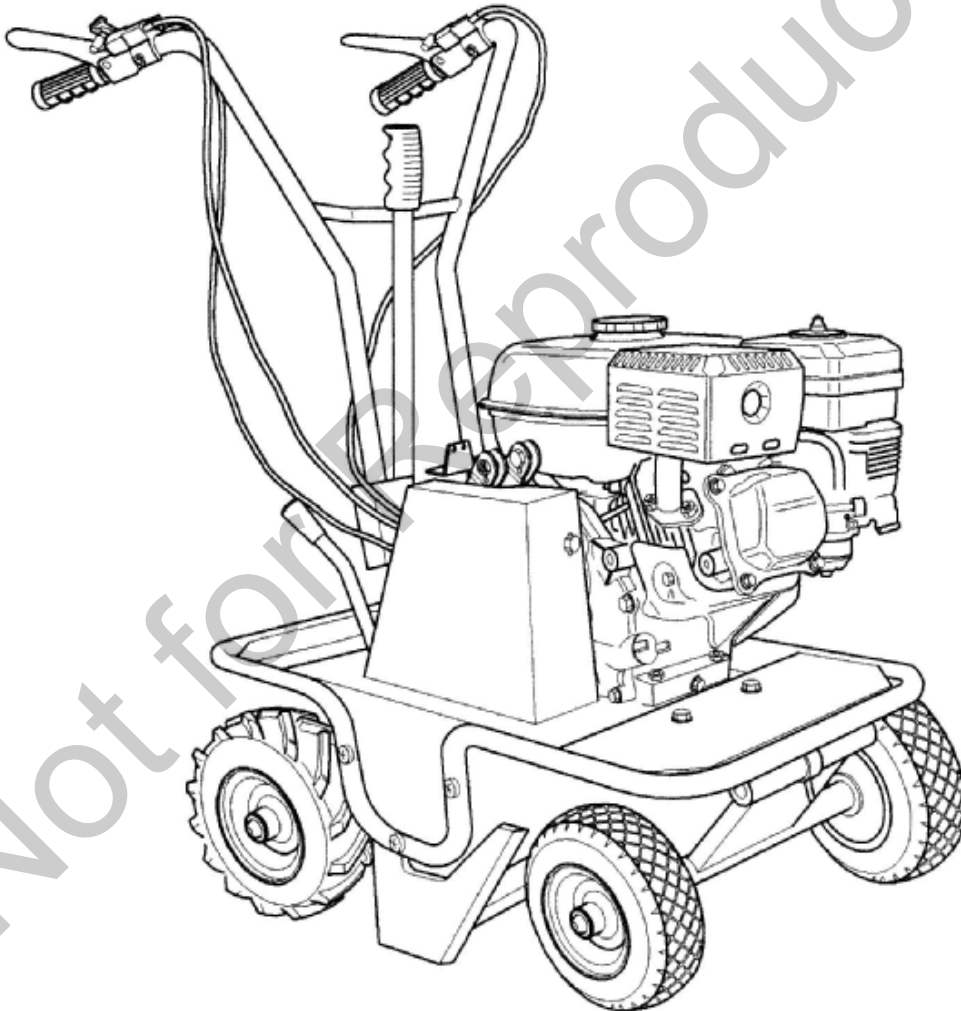

MODEL SC121H



OPERATING AND SAFETY INSTRUCTIONS

Not for Reproduction

- SOD CUTTER MANUAL - CONTENTS

1.	USE OF THE MANUAL.....	page 4
2.	NOTICES ON THE MACHINE.....	page 5
3.	TECHNICAL DATA.....	page 7
4.	LIFTING AND TRANSPORTATION.....	page 8
5.	MAIN PARTS OF THE MACHINE.....	page 9
6.	CONTROLS AND ADJUSTMENTS.....	page 10
7.	ASSEMBLY INSTRUCTIONS FOR THE HANDLEBARS AND END PART OF THE CUTTING HEIGHT ADJUSTMENT LEVER.....	page 11
8.	SAFETY INFORMATION	
	A) GENERAL INSTRUCTIONS.....	page 12
	B) TRAINING.....	page 12
	C) PREPARATION.....	page 12
	D) WORKING USE.....	page 13
	E) AFTER USE.....	page 15
9.	TRANSPORTATION OF THE MACHINE.....	page 15
10.	DESCRIPTION OF THE SAFETY SYSTEMS AND GUARDS.....	page 16
11.	OPERATIONS TO BE CARRIED OUT BEFORE SWITCHING ON.....	page 16
12.	STARTING AND DRIVING THE TURF CUTTER.....	page 17
13.	CUTTING TIPS.....	page 19
14.	CHECKS	
	A) TYRE PRESSURE.....	page 19
	B) CABLE CONTROL ADJUSTMENT	page 19
	C) BELT REPLACEMENT AND ADJUSTMENT.....	page 20
	D) SERVICE BRAKE CHECKING.....	page 21
	E) CHECKING AND REPLACING THE BLADE.....	page 24
15.	MAINTENANCE AND STORAGE.....	page 25
16.	CLEANING THE MACHINE.....	page 26
17.	SEASONAL LONG-TERM STORAGE PERIODS.....	page 26
18.	DECOMMISSIONING AND SCRAPPING.....	page 27
19.	TECHNICAL ASSISTANCE.....	page 27
20.	WARRANTY.....	page 27
21.	TROUBLESHOOTING.....	page 28

OPERATING AND SAFETY INSTRUCTIONS

SOD CUTTER MODEL SC121H

FOREWORD

This machine may only be utilized for the purpose for which it was designed, i.e. to cut 30cm-wide strips of turf.

Any other use other than that stated, not covered or deducible from this Manual and the enclosed Engine Manual is "PROHIBITED".

Failure to comply with instructions in this Manual and in the Engine Manual releases the manufacturer from all liability, in particular for any damage resulting from improper or incorrect use, through negligence, superficial interpretation or flagrant disregard for the safety requirements herein.

Get your dealer to explain how to use the machine in optimum safety conditions.

Always perform the checks as prescribed herein before each work session with the machine. Should any information given in the following pages be unclear or not straightforward please contact the manufacturer directly.

1. USE OF THE MANUAL

This Manual consists of numbered pages and enclosures featured in the list of contents. Before operating the machine the user must read the instructions in the Operator's Manual carefully as well as those of the Engine Manual enclosed.

Use of the turf cutter by more than one operator (individually), means that they must have carefully read the Operator's Manual and the Engine Manual **before using it**.

The aforementioned manuals form an integral part of the machine and must therefore be kept intact and in good condition, in a known, easily accessible place for the entire working life of the machine, even if the turf cutter is passed on to another owner. The purpose of these manuals is to provide the information necessary for the safe and competent use of the product. In the instance of wear or purely for a greater technical working knowledge, the manufacturer may be contacted directly. The Notes Section at the end of the Turf cutter Manual is for the addition of any complementary notes.

In this Manual all safety information appears in special boxes headed "WARNING".

WARNING

This heading is used to draw the user's attention to hazardous areas or moving parts of the machine. It is also used in instances where failure to comply with the instructions given may result in injury to persons and animals or damage to property.

2. NOTICES ON THE MACHINE

WARNING

The Engine Exhaust from this product contains chemicals known to the State of California to cause cancer, birth defects or other reproductive harm.

The symbols affixed to the machine serve to warn of danger during its use and maintenance. It is vitally important to understand the meaning of the danger notices and all messages should be kept in legible condition. In the instance of wear these notices should be replaced and use of the machine suspended while without such notices.

The operator is advised to observe the warnings given on the affixed notices.

The symbols affixed to the machine serving to warn of danger during its use and maintenance are as follows:



400268 - Label Hot Engine, Qty. 1



400424 - Label Warning, Qty. 2

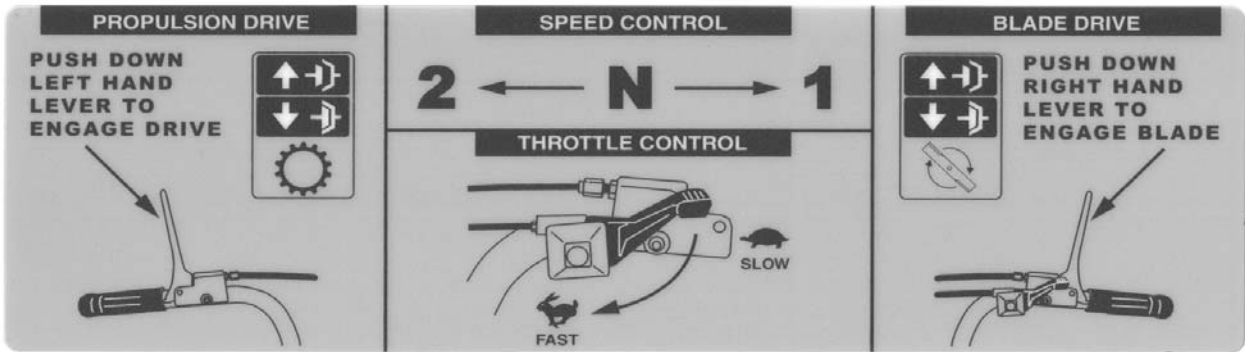

370405 - Label Controls Instruction, Qty. 1

OPERATING INSTRUCTIONS

SOIL SHOULD BE DAMP WHEN CUTTING SOD.

1. LOWER CUT HEIGHT ADJUSTMENT LEVER TO DESIRED DEPTH. THIS WILL RAISE THE REAR WHEELS OFF OF THE GROUND.
2. MOVE TRANSMISSION SHIFT LEVER INTO DRIVE POSITION
3. ENGAGE CUTTING BLADE HAND CONTROL AND ALLOW BLADE TO CUT INTO THE TURF UNTIL THE REAR WHEELS ARE RESTING ON THE GROUND.
4. ENGAGE THE WHEEL DRIVE HAND CONTROL TO BEGIN FORWARD MOTION.
5. RELEASE BOTH HAND CONTROLS TO STOP THE CUTTER AT THE END OF THE CUT.
6. RAISE THE BLADE DEPTH CONTROL TO LIFT THE BLADE OUT OF THE GROUND.
7. ENGAGE BOTH HAND CONTROLS TO ALLOW THE BLADE TO CUT THROUGH THE SOD.

 **READ OWNERS MANUAL BEFORE OPERATING.**

USE PERSONAL PROTECTION



370300 - Label Instructions, Qty. 1

3. TECHNICAL DATA FOR THE SOD CUTTER SC121H

ENGINE :	Gasoline, HONDA GX 160 K1
ENGINE CAPACITY :	5.5 Hp (4.0 kW)
CUTTING WIDTH :	12" (30 cm)
CUTTING HEIGHT :	adjustable up to 35 mm
SPEED GEARS :	2 forward gears
TRANSMISSION :	mechanical
GEARS :	in oil bath
START :	recoil
HANDLEBARS :	height-adjustable
TYRES :	front tyres GARDEN 3.00-4 rear tyres TRACTOR 3.00-4
DIMENSIONS L x W x H (mm) :	780 x 420 x 610 mm
WEIGHT (kg) :	73

ACOUSTIC PRESSURE, measured according to EN 12733:	86,2 dBA
ACOUSTIC POWER, measured according to EN 12733:	LWA 97 dBA
VIBRATION LEVEL TRANSMITTED TO THE HANDLEBAR (EN 12 733) AW:	1,8 m/s ²

Environmental conditions

Unless otherwise stated at the time of ordering it is understood that the machine is to work normally in the environmental conditions covered by the following points.

Environmental conditions other than those described may cause mechanical breakage resulting in the creation of dangerous situations for persons.

ALTITUDE

The altitude of the place in which the machine is to be used must not exceed 1500 m above sea level.

TEMPERATURE

Minimum ambient temperature: -5°C

Maximum ambient temperature: +50°C

ATMOSPHERIC CONDITIONS

The electrical equipment will function correctly in atmospheric conditions with a relative humidity up to 50% at a temperature of 40°C and at 90% with a temperature up to 20°C (without condensate).

ATMOSPHERE WITH RISK OF EXPLOSION AND/OR FIRE

The standard machine herein described is not designed to work in explosive atmospheres or in those with risk of fire.

4. LIFTING AND TRANSPORTATION

All material is carefully checked by the manufacturer before shipping. The turf cutter is delivered in a cardboard box with the handlebars and end part of the cutting height adjustment lever disassembled.

Upon receipt of the machine make sure that it has not been damaged during transit and that the packaging has not been tampered or any parts removed. Report any damage or missing parts immediately to the carrier and the manufacturer with photographic documentation.

After assembling the handlebars and the end part of the cutting height adjustment lever as per the instructions given in paragraph 7 of this manual, the machine may be moved on its own wheels.

The manufacturer is not liable for any damage caused by transportation of the machine after its delivery.

WARNING

Extreme care must be taken during handling to prevent overturning. Avoid steep gradients to prevent loss of control.

Make sure that there are no persons present within the danger area.

5. MAIN PARTS OF THE MACHINE

The machine consists of the following main parts:

- A - BLADE CLUTCH CONTROL LEVER
- B - ACCELERATOR CONTROL LEVER
- C - FORWARD CLUTCH CONTROL LEVER
- D - CUTTING HEIGHT ADJUSTMENT LEVER
- E - ENGINE
- F - COVER
- G - BLADE
- H - FORWARD-NEUTRAL GEAR SELECTOR LEVER
- I - ON/OFF SWITCH (1/0)

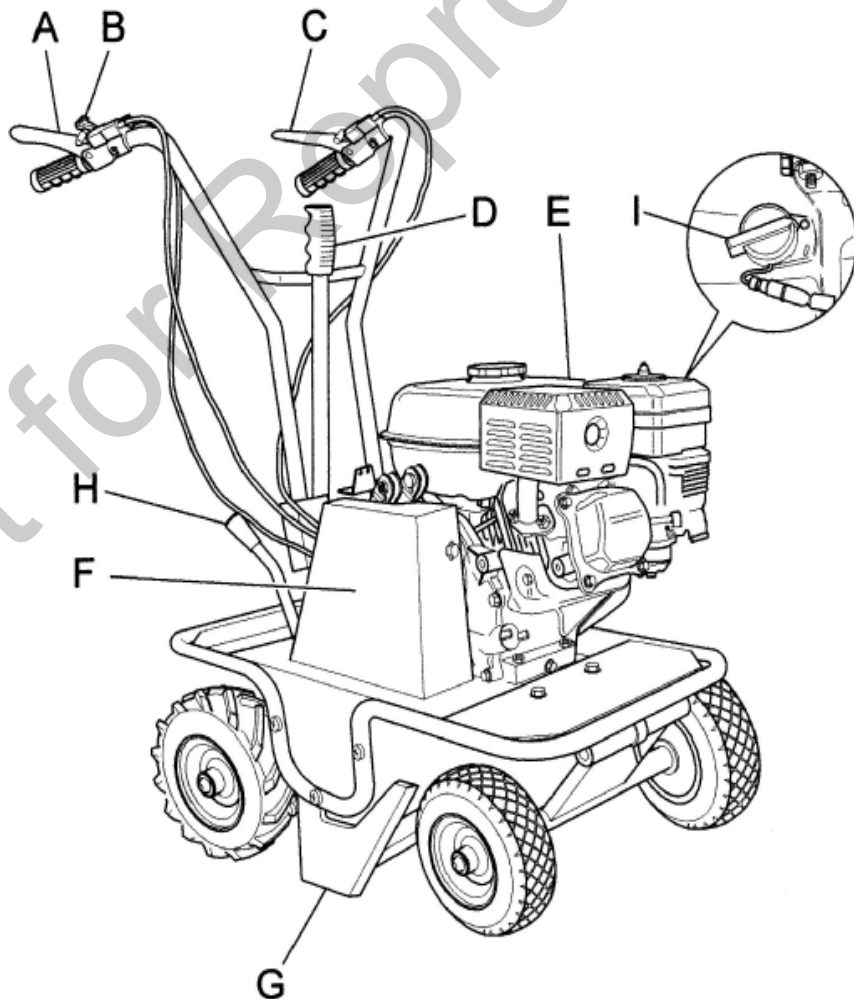

Figure 1

6. CONTROL AND ADJUSTMENTS

A) BLADE CLUTCH CONTROL LEVER

This is used to engage and disengage the blade movement. Lowering the lever engages the clutch and releasing it disengages the clutch.

WARNING

The blade will continue to move if the engine is running and the blade clutch is engaged, regardless of the position of the forward clutch.

B) ACCELERATOR CONTROL LEVER

This is used to adjust the number of engine revolutions according to the operations to be carried out. Hence at switch on the lever will be positioned on the minimum setting whilst during work operations it will be positioned as required by use.

C) FORWARD CLUTCH CONTROL LEVER

This lever only has two positions: engage and disengage. Lowering the lever engages the clutch and releasing it disengages the clutch.

This lever automatically operates the service brake: when released the lever engages the brake, when engaged the lever disengages the brake.

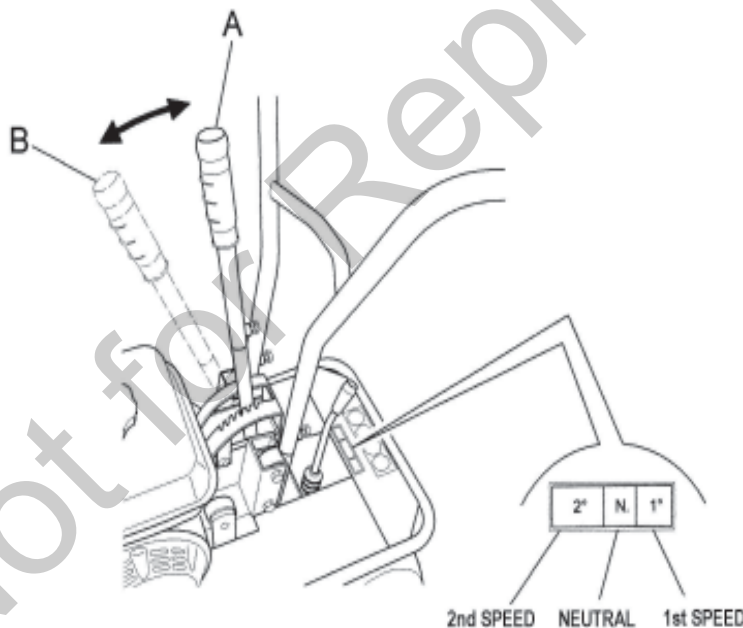

Figure 2

D) CUTTING HEIGHT ADJUSTMENT LEVER

This lever serves to adjust the cutting height according to the type of terrain and the thickness of the turf to be cut. (Fig.2 Ref. A)

F) COVER

The cover (Fig. 1, ref. F) prevents any contact with the moving parts of the machine. Use of the machine without the said cover is strictly prohibited.

I) ON SWITCH

Two-position switch:

(1) for starting the engine

(0) for switching off the engine

L) FORWARD-NEUTRAL GEAR SELECTOR LEVER

This lever selects the gear forward (1st, 2nd) or neutral.

WARNING

Select the required gear only after disengaging the forward clutch by releasing the relative lever (Fig. 1, ref. C).

7. ASSEMBLY INSTRUCTIONS FOR THE HANDLEBARS AND END PART OF THE CUTTING HEIGHT ADJUSTMENT LEVER

The turf cutter is delivered with the handlebars and the end part of the cutting height adjustment lever disassembled. Remove the cardboard packaging (to be disposed of in an appropriate manner, in accordance with current regulations in force).

To assemble proceed as follows :

- Lift the handlebar (Fig. 3 Rif. C) and insert it in the supports shown in Fig. 3 rif. E. Select the required cutting height and secure the setting using the screws provided (Fig. 3 ref. D).
- Fit the end part of the cutting height adjustment lever (Fig. 3 Ref. A) into its relative support (Fig. 3 ref. F) and secure using the screw provided (Fig. 3 Ref.B).

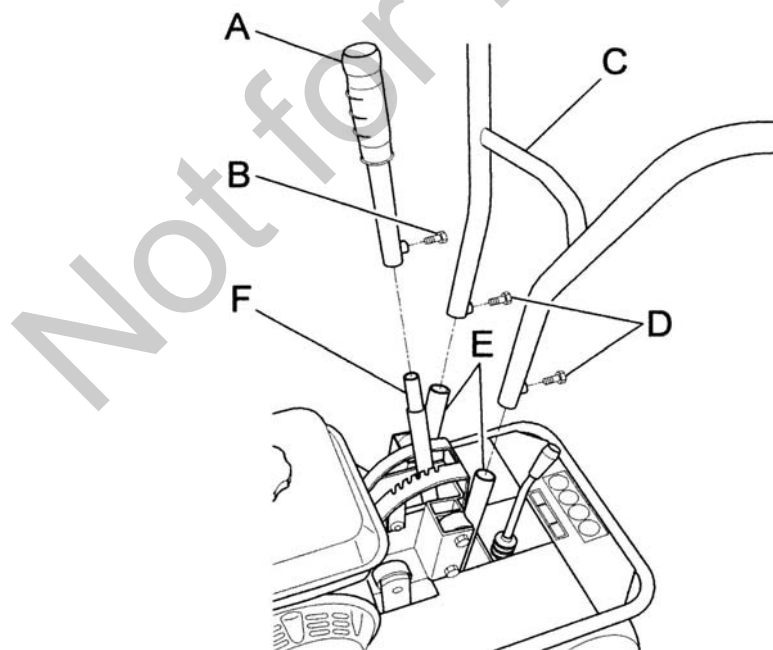

Figure 3

Before switching on ensure that the machine has been fully assembled correctly.

8. SAFETY INFORMATION

Before using the turf cutter it is essential that the operator has understood the warnings, do's and don'ts and precautionary measures given in this manual and in the engine manual: the prevention of injury to the operator, third parties, animals or objects directly depends on observance of these instructions.

A) GENERAL INSTRUCTIONS

- Use of the turf cutter for purposes other than those envisaged is strictly prohibited.
- Climbing aboard and/or riding on the turf cutter is strictly prohibited.
- Tampering with the safety systems and guards is strictly prohibited.
- Modifications to devices/components not envisaged by the manufacturer are strictly prohibited.
- The electrical parts of the engine must be protected at all times.

B) TRAINING

- Read the Operator's Manual and the Engine Manual before using the machine.
- Use of the machine by minors under the age of 16 years or by persons without the necessary psychological and physical capabilities is forbidden.
- Do not use the machine near other persons or within enclosed areas.
- The placing of hands, other parts of the body and clothing in the moving parts of the machine is prohibited.
- It is forbidden to approach the moving parts.
- Before carrying out any inspection or servicing operations make sure that the engine has been switched off and the spark plug wire removed.

C) PREPARATION

- Make sure that the working area around the machine is free of obstacles and has sufficient lighting.
- Before switching on the engine make sure there are no persons, animals or vehicles in the vicinity .
- Before switching on the engine make sure that both engagement levers (forward clutch control lever - Fig. 1, ref. C and blade clutch control lever - Fig. 1, ref. A) are in the disengaged position (released) ; then place the gear lever in neutral (Fig. 2, ref. C)
- Before switching on the machine make sure that the screws, fixing elements and protection devices are in place and that the affixed notices are legible.
- Then: Make sure that the wheel fixing bolts have been tightened fully.
- Secure all blade nuts and fixing bolts to prevent their loss during work operations. Replace any old or worn blades.
- The cover (Fig. 1, ref. F) should not be moved for any reason whatsoever while the machine is in use.
- When switching on the engine check the position of the various control levers (see the section on "Controls and adjustments").

- Supervise the clothing of personnel operating the machine: a long-sleeved jacket with close-fitting cuffs, long, close-fitting trousers, heavy-duty footwear, and a protective cap or helmet should be worn. Avoid wearing loose-tailed clothing, unbuttoned jackets or torn, undone or partially zipped up items to prevent them from being caught up in the moving parts.
- Safety goggles and ear protection devices must be worn. Safety gloves must also be worn during machine operation and maintenance.
- Do not switch on and operate the turf cutter in enclosed areas since the engine gives off carbon monoxide fumes which are colourless, odourless, tasteless and extremely dangerous.
- Take care when handling fuel. Fuel is highly flammable and its vapours explosive :
 - Only use an approved container
 - Take care not to remove fuel caps or top up the tank with the engine running.
 - Allow the engine to cool before proceeding with fuel-filling operations.
 - Do not smoke during this operation.
 - Never fill the machine with fuel in an indoor ambient
 - It is advisable to use a wide funnel to prevent spillage of fuel on the engine and on other surfaces of the turf cutter.
 - If any fuel is spilled do not attempt to switch on the engine; simply move the machine away from the area of spillage before switching on.
 - After filling up with fuel reposition and screw the fuel tank cap right down.
- Do not rest the turf cutter or the fuel container in indoor environments with naked flames

D) WORKING USE

- When working keep everyone at a minimum distance of 10 metres from the machine.
- Keep the engine well ventilated and clog-free (materials and other residue) to prevent damage to the engine and risk of fire. **Clean the cooling fan and fins regularly.** Clean the air filter at the same time as well.
- Drive smoothly, avoiding brusque starts, braking and turns.
- Take care not to touch the silencer when hot.
- If a slipping belt causes abnormal noise, smells or overheating, switch off the engine immediately and check the machine to prevent the outbreak of fire and damage to the transmission.
- The blade is extremely dangerous. Take great care during operation. Do not use feet or hands to push the machine down into the turf and do not allow anyone to stand either in front of the machine or in its direction of travel.

WARNING

During operation the lawn and turf are cut into strips. Should the cutter's wheels skid during use it is advisable to adjust the cutting height using the special lever (Fig. 3, ref.A). If this operation does not prevent this occurrence check the state of the terrain. If it is too dry it should be wetted so that the blade encounters a slight resistance, thus making cutting operations easier.

WARNING

When working in a stony or obstacle-riddled area try to remove as many objects as possible before commencing cutting. Then work at a greater cutting height than usual.

WARNING

Stones and other objects may be thrown outwards in direction of the operator or of other persons in the vicinity. Keep at a safe distance from persons, animals and objects.

- If the cutting mechanism accidentally comes into contact with an object (stump or stone), switch off the engine and carry out the following operations:
 - Inspect the damage
 - Do not attempt to repair it if unskilled to do so
 - Check that no parts have come loose
- Do not use the machine if it does not work properly or is broken: seek authorized service.
- It is strictly prohibited to leave the turf cutter running whilst unsupervised.
- It is strictly prohibited to transport the machine with the engine running. When loading the machine onto a vehicle, the inclination of the ramps must not exceed 15°.

WARNING

EXERCISE CAUTION WITH GRADIENTS. Danger of machine overturning.

- Given its outdoor use, it is advisable not to use the turf cutter when it is raining.
- The area next to the engine exhaust may reach a high temperature.

WARNING

Danger of burns.

- Do not go near water fountains or precipices and do not cross narrow bridges during work operations to prevent the risk of falling.
- Do not work on steep banks.
- In the instance of difficulty or emergency stop simply release the forward clutch control and blade movement levers and return the gear lever to neutral position.
- Work on flat ground for the utmost safety.

E) AFTER USE

- Before moving away from the machine, place the gear lever in neutral (Fig. 2, ref. C) and switch off the engine by moving the switch (Fig.1,ref.I) to the 0 position.
- For greater safety shut off the feed cock (Fig. 4).

9. TRANSPORTATION OF THE MACHINE

LOADING AND UNLOADING FROM A VEHICLE

- For transportation it is preferable to use a vehicle with an open bed.
- Choose firm, flat ground.
- Switch off the vehicle's ignition, put into reverse gear, pull on the hand brake and block the tyres with chocks to prevent accidental movement of the vehicle.

WARNING

Raise the blade to maximum height to prevent danger of its catching the ramp edges.

- Do not stand in front of the machine
- Firmly hook the loading ramps onto the vehicle bed.
Use stable load ramps with a non-slip surface strong enough to take the weight of the machine. The inclination of the ramps must not exceed 15°.
Recommended length : at least 3 $\frac{1}{2}$ times the vehicle bed's height from the ground.
Recommended width : to be chosen according to the tyre width of the machine
- Proceed with the loading of the machine, manoeuvring it carefully. Set the accelerator lever at minimum (Fig. 1, ref. B) and using the lever as shown in figure 2, ref. C, engage the forward gear for loading, or the reverse gear for unloading.
- During loading/unloading operations on the ramps avoid operating the blade clutch (Fig. 1, ref. A) and the gear lever (Fig. 1, ref. H) because such actions may prove extremely dangerous.
- Line the front wheels up with the centre of the loading ramps.
- Take care when the machine passes from the loading ramps to the vehicle bed, because a shift in balance occurs.
- Once loaded, turn off the engine using the relative switch (Fig. 1, ref. I), make sure that the service brake has automatically come into operation upon release of the forward clutch control lever (fig. 1, ref. C), block the machine wheels using chocks and firmly tie the machine to the vehicle.

10. DESCRIPTION OF THE SAFETY AND GUARD SYSTEMS

WARNING

The safety devices must never be tampered with. It is necessary to understand how they work and safeguard their efficiency and correct operation. In the instance of doubt, problems or malfunction contact your dealer.

FORWARD CONTROL AND BLADE MOVEMENT LEVERS

When released both of these levers instantly disengage the transmission connected to them. In this way they act as safety devices.

In the instance of difficulty or sudden emergency, the quick release of these levers will return them to their standard position (raised).

COVER

The cover (Fig. 1 point F) partially protects the machine from any projected objects and contact with the moving blade. Use of the machine without the said cover is strictly prohibited.

The cover should only be removed when replacing belts with the machine switched off.

11. OPERATIONS TO BE CARRIED OUT BEFORE SWITCHING ON

Position the turf cutter outdoors on sufficiently firm, flat soil. Read the instructions provided by the engine manufacturer in the relative manual and follow them carefully to prevent situations arising which may endanger either persons or the machine.

WARNING

New machines straight from the factory do not have any engine oil.

Then check:

- the state of the blade by inspecting them;
- that all the screws are tightened, particularly those securing the blade;
- that the guards and safety devices are securely tightened.
- Before switching on the turf cutter make sure that there are no persons in the vicinity.
- During operation do not allow persons near the machine, especially children. The operator is responsible for any harm done persons in the working area of the machine.

Oil recommendations

The engine is supplied without oil. Before starting up the engine fill with oil and check the oil level with the engine in a horizontal position. Do not overfill.

Use of a high-grade detergent oil is recommended (refer to the enclosed engine manual).

Fuel recommendations

Use of fresh, clean lead-free petrol is advised.

WARNING

It is advisable to consult the engine manual before switching on the machine.

12. STARTING AND DRIVING THE TURF CUTTER

The machine can be switched on once all the aforementioned preliminary operations have been carried out.

Place the feed cock in the OPEN position (direction shown by the arrow, Fig. 4).

Bring the choke to the CLOSED position for a cold start (direction shown by the arrow, Fig. 4a).

Set the accelerator lever at the minimum position.

Grip the engine pull lead handle (fig. 4b) and pull gently until you feel the “bite”, then pull on the lead sharply to overcome the pressure, prevent kickback and switch on the engine.

Repeat the procedure, if necessary, with the accelerator lever in INTERMEDIATE position.

Once the engine is running, set the accelerator in the MINIMUM position and gently return the choke to the OPEN position (Fig. 4a).

Cleaning of the machine is recommended after use (see the section “Cleaning the machine”).

Figure 4

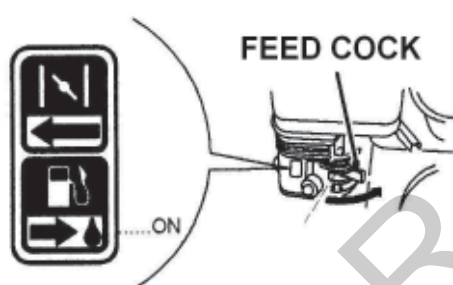

Figure 4a

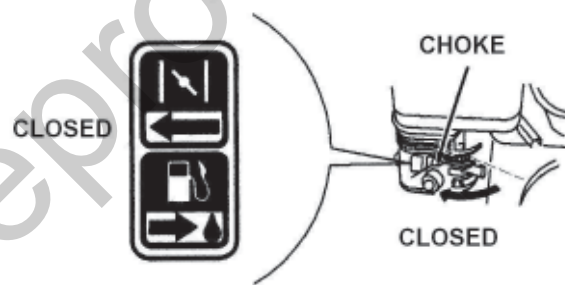
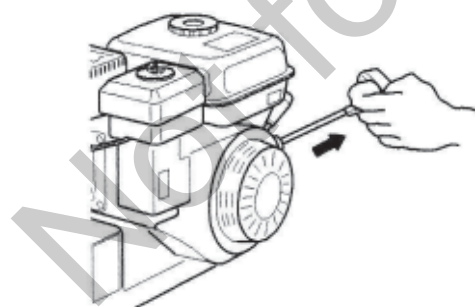

Figure 4b



DRIVING THE MACHINE

WARNING

When using the machine for the first time it is advisable to get the feel of it by executing manoeuvres on flat ground free of foreign objects.

After switching on the engine following the instructions given in the previous paragraph:

1. Move the gear lever (fig. 2) to the 1st speed position.

WARNING

If the gear engages with difficulty, partially engage the clutch for an instant before trying to engage the gear again.

2. Engage the blade control level using the relative lever (Fig. 1, ref. A).

WARNING

Choose a cutting height suitable for the type of terrain the machine is to be used on.

3. To move the machine, accelerate and then engage the forward clutch using the relative lever (Fig. 1, ref. C).
4. To select a different gear the forward clutch and the blade clutch must first be disengaged by releasing their levers (Fig. 1, ref. C and Fig. 1, ref. A). Then select the desired FORWARD position (1°- 2°, in fig. 2) using the gear lever (Fig. 2), then re-engage the forward clutch control lever (Fig. 1, ref. C) to set the machine in motion again.
5. To stop the blade release the relative lever (Fig. 1 ref. A).
6. To stop forward movement of the machine release the relative lever (Fig. 1, ref. C), then switch off the engine by moving the switch to the position (O) (Fig. 1, ref. I).

13. CUTTING TIPS

1. Before commencing cutting operations, read the safety instructions given in the previous sections.
2. At first the setting of a relatively high cutting height is recommended (using the relative lever in figure 2, ref. A), lowering it gradually according to working conditions.
3. Engage the blade clutch (Fig. 1, ref. A) only after having carried out the machine switch-on and gear engagement operations.
4. Before engaging the blade clutch (Fig. 1, ref. A), gradually move the accelerator (Fig. 1, ref. B) until the required speed is reached.

WARNING

Take great care because the blade moves at very high speed.

14. CHECKS

- Adjust the belt and cable control tension after the first few working hours to compensate initial loosening.
- Briefly operate all the machine's components to detect any abnormal noises or overheating.
- During the initial running in period avoid heavy-duty usage to encourage proper settling of the mechanical parts.
- Never neglect maintenance operations after work and carry out all prescribed checks regularly.

A) TYRE PRESSURE

Regularly check the tyre pressure. If both two tyres are not inflated to average pressure the machine will tend to travel sideways during operation.

B) CABLE CONTROL ADJUSTMENT

To adjust the cables place the machine on flat ground, switch off the engine and disconnect the wire from the spark plug.

B1)BLADE CONTROL CABLE

Make sure that there is no play between the upper end of the cable and the adjustment screw. If there is, or if the cable has stretched, restore to ideal position using the relative adjustment screw(Fig. 5, ref. A).

If adjustment using the relative screw proves ineffective, the belts, and hence the engine mounting, must be adjusted. To perform this operation refer to section 14C " BELT REPLACEMENT AND ADJUSTMENT" of this manual.

B2) FORWARD CONTROL CABLE

Make sure that there is no play between the upper end of the cable and the adjustment screw. If there is, or if the cable has stretched, restore to ideal position using the relative adjustment screw (Fig. 5, ref. A).

If adjustment using the relative screw proves ineffective, the belts, and hence the engine mounting, must be adjusted. To perform this operation refer to section 14 C “ BELT REPLACEMENT AND ADJUSTMENT” of this manual.

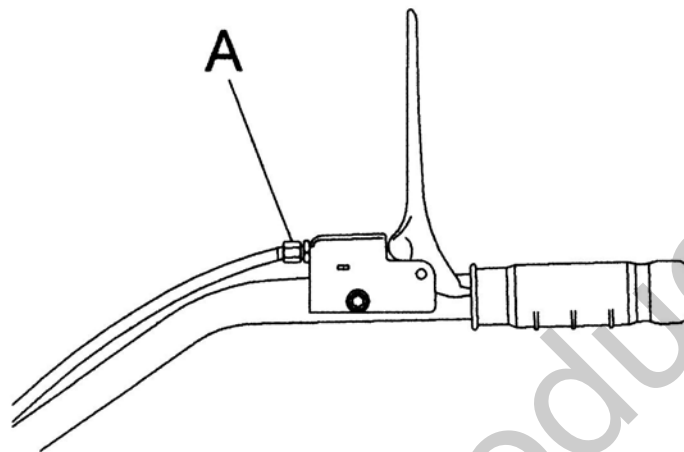

Figure 5

C) BELT REPLACEMENT AND ADJUSTMENT

Switch off the engine and disconnect the spark plug wire before carrying out any maintenance or repair work on the machine.

If a belt is worn or breaks it should be replaced as follows:

- remove the metal guard (fig. 6 ref. A), by unscrewing and taking out the screws shown in figure 6 ref. B and C.

C1) BLADE BELT

Disconnect the connecting rod (Fig. 7 Ref. B) by removing the nut and loosening the screw that secure it to the arm (Fig. 7 Ref. C)

- Once the connecting rod has been disconnected the belt can be slipped off (Fig. 7 Ref. A) by manually turning the relative lower pulley anticlockwise (Fig. 7 Ref. D).
- To fit the new belt follow the procedure in the reverse order.
- Afterwards check that the belt is correctly positioned by using the relative blade control lever. When this lever is lowered and the belt is at maximum tension, the distance between the belt and the relative belt guides (Fig. 7 Ref. E) should be approximately 2 mm.
- Then make sure that the belt works properly by tugging lightly on the self-winding starter cable with the engine switched off and the spark plug wire disconnected. If everything is working properly the pulley will turn on the engine but will not engage the belt.

If the belt engages push the engine back slightly towards the rear of the machine (in the direction of the handlebars) until the belt is in the correct position.

C2) FORWARD CONTROL BELT

Remove the blade control belt following the instructions given in the preceding paragraph.

- Remove the blade (Fig.1 Ref. G) following the instructions provided in the section entitled "Blade removal and replacement".
- Then remove the forward control belt from the lower pulley by turning the belt anticlockwise (Fig. 8 Ref. A e B)
- To fit the new belt follow the procedure in the reverse order.
- Afterwards check that the belt is positioned and working correctly using the relative forward control lever. When this lever is lowered and the belt is at maximum tension, the distance between the belt and the relative belt guides (Fig. 8 Ref. C) should be approximately 2 mm.
- Then make sure that the belt works properly by tugging lightly on the self-winding starter cable with the engine switched off and the spark plug wire disconnected. If everything is working properly the pulley will turn on the engine but will not engage the belt. If the belt engages push the engine back slightly towards the rear of the machine (in the direction of the handlebars) until the belt is in the correct position.

D) SERVICE BRAKE CONTROL LEVER

The service brake (Fig. 9 Ref. A) is connected to the forward control lever (Fig. 1 Ref. C). With the forward control lever released and the brake engaged ensure that there is play of approximately 2 or 3 mm between the adjustment screw and the brake cable (Fig. 9 Ref B and C).

WARNING

If there is no such play restore it immediately since the brake will not stop the machine once the forward control lever is released. Make sure that the front part of the brake in direct contact with the pulley (Fig. 9 Ref. D) is not worn. If so, replace it.

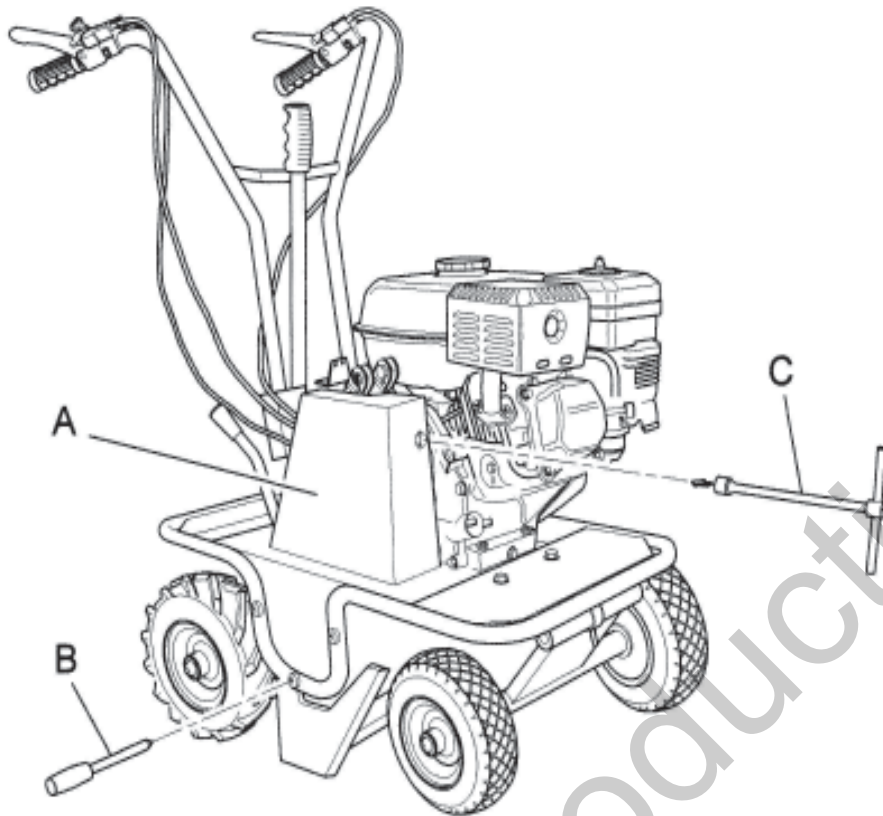

Figure 6

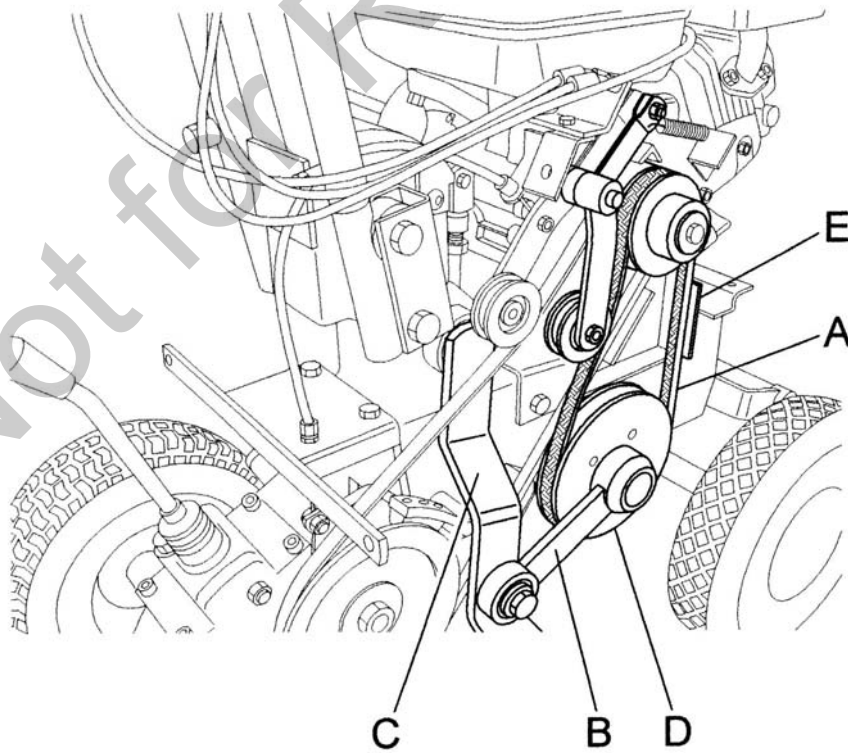

Figure 7

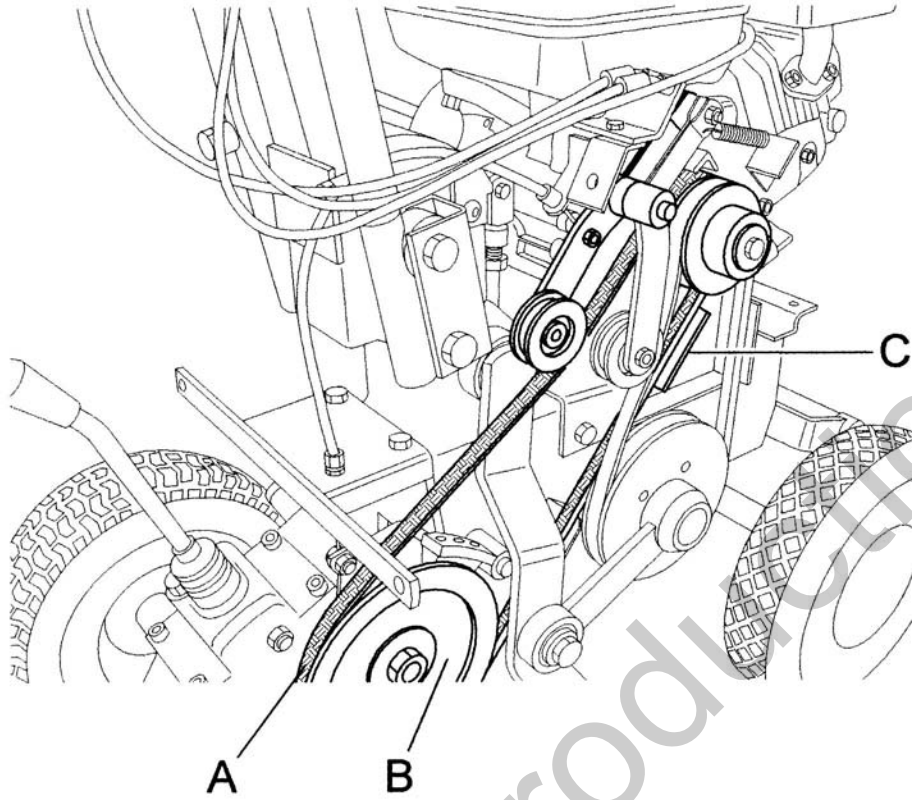

Figure 8

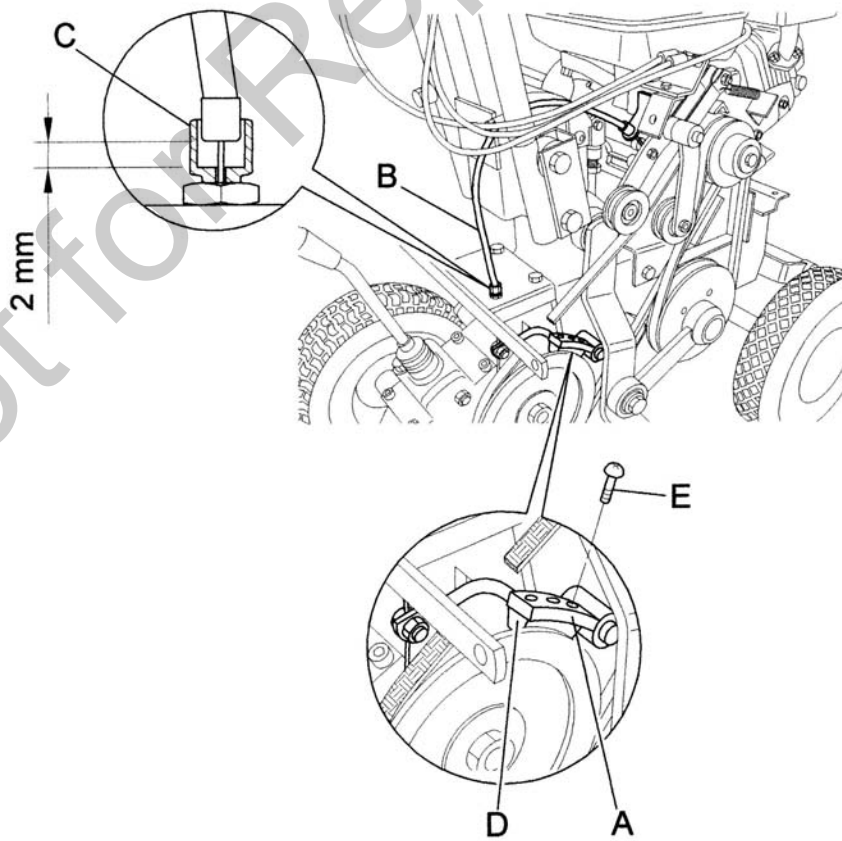

Figure 9

E) CHECKING AND REPLACING THE BLADE

Always check the state of the blade before commencing work. Do not forget to switch the engine off!

- During work operations if the blade (Fig. 10, ref. A) strikes stones or stumps stop straightaway and make sure that it has not become bent or broken. A damaged blade must be replaced.
- If the blade is very worn, cracked or bent, it makes snap and projects objects outwards, risking serious accident.
- Use heavy-duty work gloves to check or replace the blade to avoid risk of injury to hands.
- The blade fixing screws and relative nuts are also subject to wear. Always replace them at the same time as the blade, using bolts and screws of the same strength and type.
- The blade wears more quickly on dry, sandy ground. In these conditions it should be replaced more frequently.

To remove the blade proceed as follows:

1. Switch off the engine and disconnect the spark plug wire
2. Adjust the cutting height to maximum
3. Check the state of the blade.

Check that the blade is not cracked, bent, excessively worn or broken.

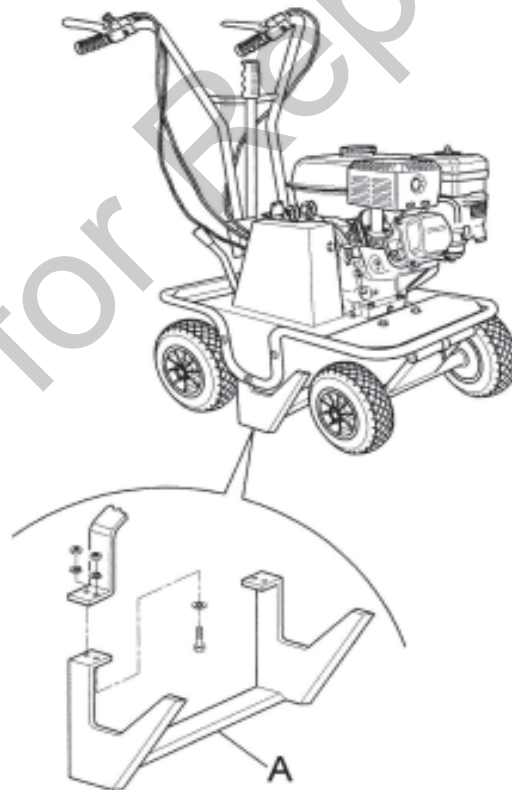

Figure 10

15. MAINTENANCE AND STORAGE

- All operations on the machine must be carried out exclusively by authorized personnel.
- Always switch off the engine when checking, adjusting or servicing the machine.
- Allow the machine to cool down before inspection.
- The cover (Fig. 1 ref. F) must always be correctly installed and intact. If it becomes damaged, have it repaired before the machine is used again.
- Make sure that all the guards of rotating and moving parts are in place.
- For greater safety, when replacing the blade replace all the fixing screws and nuts at the same time, as described in section 14, point D.
- Inspect the fuel lines. These should be replaced if damaged or after a maximum of three years, along with the fixing bands. Old lines may leak fuel.
- Check and regularly adjust the forward clutch control, blade clutch control, accelerator.
- Cover the machine with a sheet after the engine and silencer have cooled down.
- It is strictly forbidden to place/leave unattended on the turf cutter any potentially dangerous objects which may put the safety of persons or the machine at risk.
- Keep the machine in a good, clean state; do not leave it outside exposed to inclement weather conditions.
- After use store the machine in a place where children have no access. Always allow the machine to cool down before putting it away.
- After use store the machine in a place where fuel vapours cannot reach a naked flame or sparks.
- In the instance of a long period of non-use, drain the fuel tank completely.

Use of the machine does not require specific lighting.

However, the recommended minimum amount of light (e.g. 200 lux) is enough to be able to read the notices on the machine and to operate it without running risks caused by poor light.

CHECKING AND REPLACING THE TRANSMISSION OIL

Check the transmission oil level using the relative oil level screw (fig. 11 ref. C). If oil leaks out upon removal of this screw then there is enough of it in the transmission. If not, remove the filling cap shown in fig. 11 ref. A, then top up with SAE 90.

The oil should be replaced after the first 20 hours of use and after this every 100 working hours.

Remove the drainage cap shown in fig. 11 (ref. B) and allow all the oil to run out. After refitting the drainage cap, fill the transmission from the filling cap with SAE 90 transmission oil.

Refit the lid securely to prevent any leakage of oil.

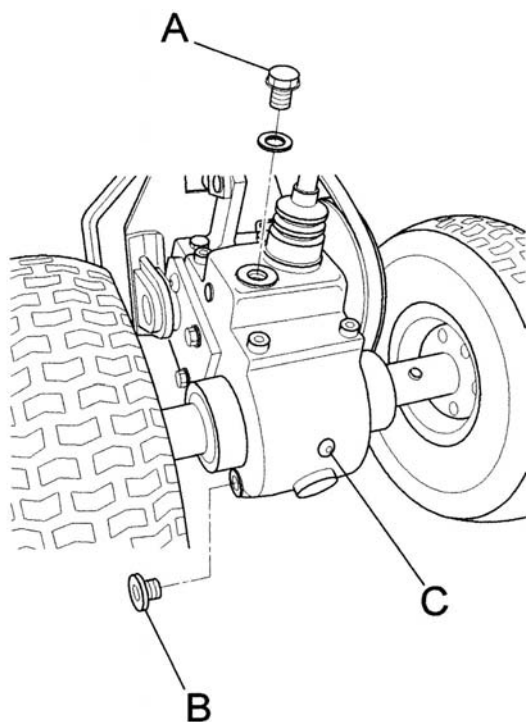

Figure 11

16. CLEANING THE MACHINE

Proceed in the following order:

- Switch off the engine and disconnect the spark plug wire;
- Clean the engine and the outside of the machine with a cloth soaked in a little oil.
- Clean all parts of the machine, particularly the starting unit, air filter, exhaust and carburetor. It is advisable to follow the instructions given in the engine manual.
- Clean the inside of the belt guard (fig. 1, ref. F) with a blast of compressed air.
- To clean the blade (fig. 1 ref. G), wash with a jet of water straight after use while still damp. When washing carefully cover and protect the electrical parts of the engine, the carburetor, the air filter and the exhaust from the water to prevent engine problems.
- To clean the blade area a tool should be used (stick of wood).

17. SEASONAL LONG-TERM STORAGE PERIODS

To store the turf cutter for prolonged periods of non-use, proceed as follows:

- Park the machine on flat, firm, clean ground.
- Oil deposits on the ground where the machine is positioned may cause irreparable damage to the tyres.
- Disconnect the spark plug wire;
- Clean the machine carefully as described in section 16 (Cleaning the machine)
- Make sure that all screws and nuts are fully tightened.
- Retouch with paint any parts which have become exposed during use.
- Store the machine in a clean, dry place.
- Empty the fuel tank, following the instructions given in the engine manual;
- Regularly check the tyre pressure, and adjust if necessary.
- Lubricate all moving parts and have any necessary repairs to the machine carried out.

18. DECOMMISSIONING AND SCRAPPING

After the working life of the turf cutter the user must have it dismantled and its components removed as per EEC directives or in accordance with current legislation in force in his country, taking particular care over the dismantling of the following materials of environmental impact:

- plastic parts
- rubber parts
- coated electric wiring
- petrol engine
- metal parts
- toxic substances

19. TECHNICAL ASSISTANCE

Routine maintenance must be carried out as per the instructions given in this Manual. For any instances not covered herein and for technical assistance in general contact your dealer referring to the data given on the identification plate affixed to the machine.

The right reference will ensure swift, precise answers.

For swift delivery of spare parts always quote the following information on the order:

- Machine model and serial number
- Part description and quantity required

For assistance concerning the engine it is advisable to contact the service centre authorized by the engine manufacturer (see engine manual supplied).

20. WARRANTY

Should a Billy Goat Machine fail due to a defect in material and / or workmanship, the owner should make a warranty claim as follows:

- The Machine must be taken to the dealer from whom it was purchased or to an authorized Servicing Billy Goat Dealer.
- The owner must present the remaining half of the Warranty Registration Card, or, if this is not available, the invoice or receipt.
- The Warranty Claim will be completed by the authorized Billy Goat Dealer and submitted to their respective Billy Goat Distributor for their territory. Attention: Service Manager. Any parts replaced under warranty must be tagged and retained for 90 days.
- The distributor service manager will sign off on the claim and submit it to Billy Goat for consideration.
- The Technical Service Department at Billy Goat will study the claim and may request parts to be returned for examination. Billy Goat will notify their conclusions to the distributor service manager from whom the claim was received.
- The decision by the Quality / Service department at Billy Goat to approve or reject a Warranty claim is final and binding.

Note: To process a Warranty Claim, it is necessary to quote the Model & Serial Number which are printed on the Billy Goat Serial Plate (See owner's manual).

21. TROUBLESHOOTING

The following table illustrates some problems which may arise during operation.

FAULT	CAUSE	MEASURES TO BE TAKEN
Belt slips	<ol style="list-style-type: none"> 1. Belt tension inadequate 2. Too great a working depth 3. Belt worn 	<ol style="list-style-type: none"> 1. Adjust the belt tension 2. Reduce the working depth 3. Replace belt
Machine vibrates excessively	<ol style="list-style-type: none"> 1. Belt damaged 2. Blade bent or broken 	<ol style="list-style-type: none"> 1. Replace belt 2. Replace blade
Engine overloads during work operations	<ol style="list-style-type: none"> 1. Engine speed too low. 2. Blade worn 3. Forward speed too high 4. Too great a working depth 	<ol style="list-style-type: none"> 1. Accelerate to maximum 2. Replace blade 3. Decrease the forward speed 4. Reduce the working depth

ENGINE

FAULT	CAUSE	MEASURES TO BE TAKEN
Engine sluggish at switch on	<ol style="list-style-type: none"> 1. accelerator not in start-up position 2. Choke not closed 3. Petrol does not arrive 4. Air bubbles or water inside the petrol lines 5. Thick oil prevents rotation 6. Winding or start mechanism faulty 7. Spark plug in poor condition 	<ol style="list-style-type: none"> 1. move the accelerator to the intermediate position 2. Close the choke when cold. 3. Check the fuel tank and remove any water or sediment.. Make sure that the feed cock is open. 4. Check the lines and bands. Repair or replace if damaged 5. Use oil with a viscosity suited to the temperature 6. Replace winding or start mechanism 7. Clean or replace spark plug. Adjust the distance between the electrodes.
Poor power	<ol style="list-style-type: none"> 1. No fuel 2. Air filter blocked 3. Elastic bands worn 	<ol style="list-style-type: none"> 1. refill tank with petrol 2. clean air filter 3. replace elastic bands
Engine stalls	<ol style="list-style-type: none"> 1. no fuel 2. feed cock shut off 	<ol style="list-style-type: none"> 1. refill tank with petrol 2. open feed cock
Exhaust fumes dark	<ol style="list-style-type: none"> 1. low grade fuel 2. too much engine oil 	<ol style="list-style-type: none"> 1. replace with high grade fuel 2. restore engine oil to correct level
Engine emits black smoke and power is poor	<ol style="list-style-type: none"> 1. air filter blocked 2. choke not fully opened 	<ol style="list-style-type: none"> 1. clean air filter 2. open the choke completely
Exhaust fumes bluish	<ol style="list-style-type: none"> 1. too much engine oil 2. elastic bands worn 	<ol style="list-style-type: none"> 1. restore engine oil to correct level 2. replace elastic bands
Silencer becomes red through overheating	<ol style="list-style-type: none"> 1. air filter blocked 2. Inside of self-winding starter blocked with grass cuttings 	<ol style="list-style-type: none"> 1. clean air filter 2. clean self-winding starter housing

For any problems not easily resolved or in case of doubt you are advised to contact your dealer.

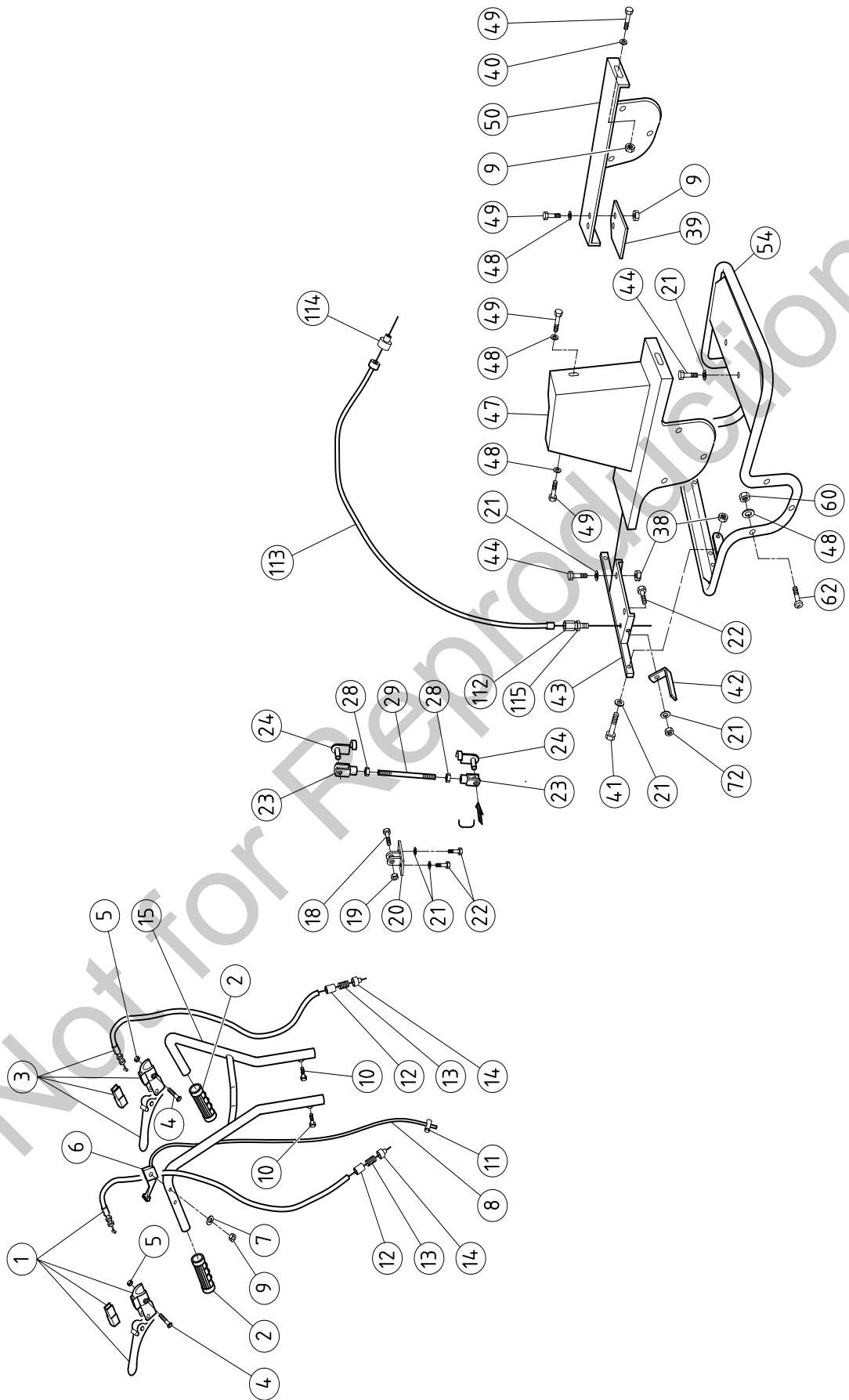

PART LIST

1/6

001	370252	LEVER CONTROL (righthand)	1
002	370257	GRIP	2
003	370253	LEVER TIGHTENER (LEFTHAND)	1
004	370178	SCREW M6X55 UNI 5931	2
005	370107	NUT LOCK M6 H6	2
006	370255	LEVER HAND ACCELERATOR	1
007	370112	WASHER FLAT M6	1
008	370254	CABLE ACCELERATOR	1
009	370148	NUT LOCK M6 H8	10
010	370281	SCREWCAP M10X20	2
011	370256	CLAMP ACCELERATOR	1
012	370186	SPRING GUIDE	2
013	370143	SPRING 10X25 C X F	2
014	370187	CABLE GUIDE	2
015	370274	HANDLE	1
018	370283	SCREWCAP M10X50 P.F.	1
019	370149	NUT LOCK M10	1
020	370248	SUPPORT LEVER HEIGHT ADJUSTMENT	1
021	370110	WASHER FLAT M8	9
022	370126	SCREWCAP M8X16	3
023	370259	FORK 03216055	2
024	370260	CLIP FORK	2
028	370146	NUT M10	2
029	370235	ROD TIE HEIGHT-ADJUSTMENT	1
038	370125	NUT LOCK M8	4
039	370280	PLATE STOPPING REVERSE GEAR	1
040	370108	WAASHER FLAT M6X18	6
041	370118	SCREWCAP M8X25	2
042	370191	BRACKET REAR	1
043	370250	SUPPORT REAR GUARD	1
044	370130	SCREWCAP M8X20	4
047	370268	GUARD BELT	1
048	370112	WASHER FLAT M6	10
049	370128	SCREWCAP M6X14	10
050	370269	GUARD SIDE (LEFTHAND)	1
054	370267	GUARD SUPPORT FRAME	1
060	370129	NUT LOCK MS H6.5	6
062	370152	SCREW CROSSHEAD MSX30	6
072	370102	NUT 8 H 6.5	1
112	370294	ADJUSTER M6 X 40	1
113	370295	CABLE CONTROL BRAKE	1
114	370296	BUSHING SHEAT	1
115	370297	NUT M6 H4	1

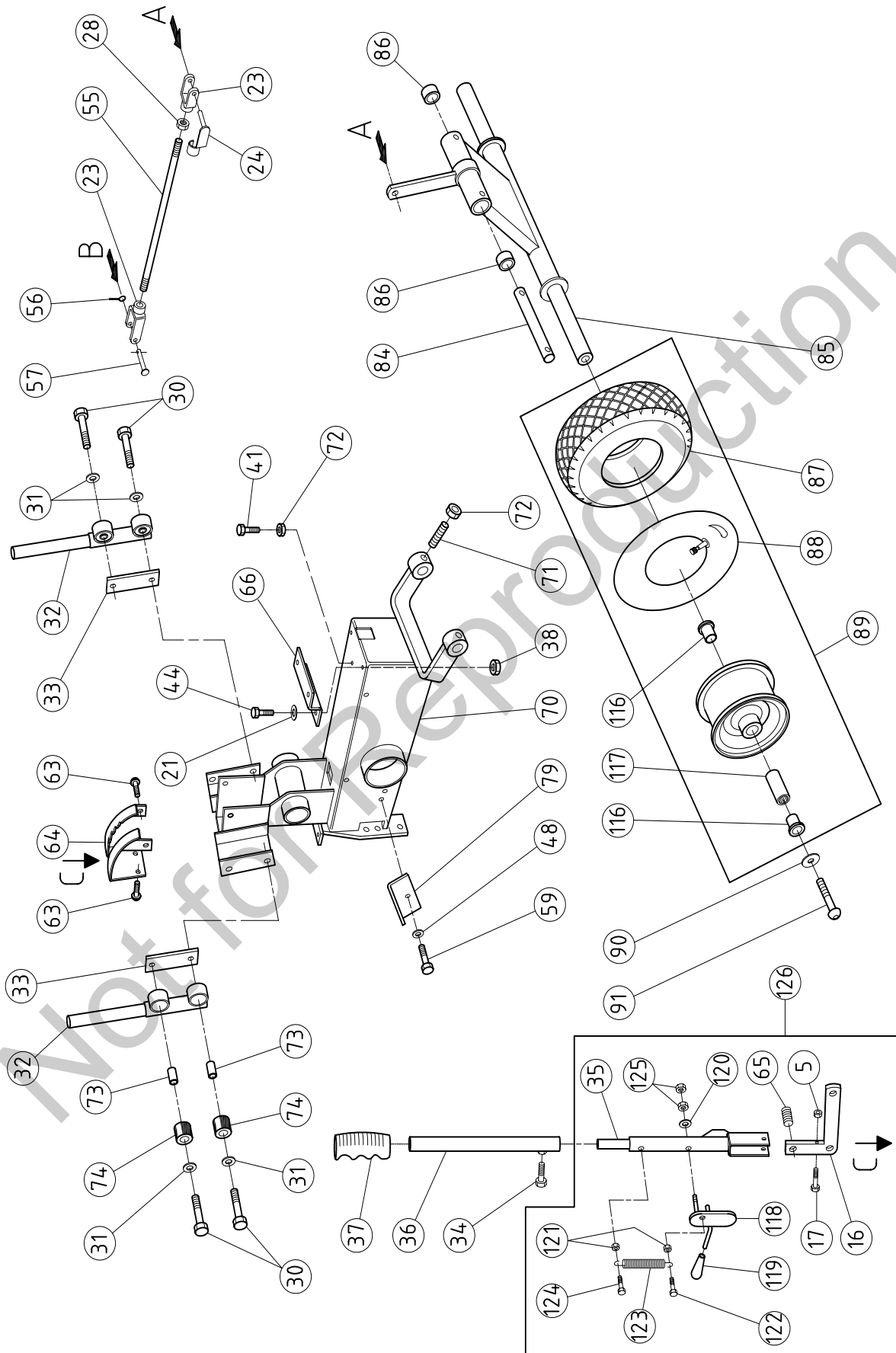

PART LIST

2/6

005	370107	NUT LOCK M6 H6	1
016	370243	LEVER	1
017	370282	SCREWCAP M6X45 P.F.	1
021	370110	WASHER FLAT M8	2
023	370259	FORK 03216055	2
024	370260	CLIP FORK	1
028	370146	NUT M10	1
030	370147	SCREWCAP M10X50 P.F.	4
031	370145	WASHER WAVE M10	4
032	370228	SUPPORT HANDLE	2
033	370247	NUT SPECIAL FOR HANDLE SUPPORT	2
034	370292	SCREWCAP M8X16	1
035	370425	LEVER HEIGHT ADJUSTMENT	1
036	370275	EXTENSION HEIGHT ADJUSTMENT LEVER	1
037	370189	GRIP 0 22	1
038	370125	NUT LOCK M8	2
041	370118	SCREWCAP M8X25	1
044	370130	SCREWCAP M8X20	2
048	370112	WASHER FLAT M6	1
055	370236	CONNECTION TIE-ROD	1
056	370151	PIN ROLL M30X2.5	1
057	370258	PIVOT Ø 10	1
059	370134	SCREWCAP M6X10	1
063	370111	SCREW BUTTON HEAD M8X12	4
064	370424	QUADRANT TOOTH HEIGHT	1
065	370144	SPRING 13X25	1
066	370251	SUPPORT FRONT GUARD	1
070	370215	BODY SOD CUTTER	1
071	370153	DOWEL M8X16	2
072	370102	NUT 8 H 6.5	3
073	370284	DAMPENER VIBRATION INTERNAL TUB 12X10X28	4
074	370285	DAMPENER VIBRATION HANDLE SUPPORT 30X12X28	4
079	370239	BLOCK SLIDING BELT No. 1	1
084	370271	PIVOT AXLE FRONT	1
085	370218	AXLE FRONT COMPLETE	1
086	370276	BUSHING SELF-LUBRICATING 16X20X22	2
087	370206	TIRE FRONT WHEEL T090700	2
088	370204	TUBE INNER FRONT WHEEL	2
089	370401	FRONT STEEL WHEEL 3.00	2
090	370119	WASHER FLAT M8X32	2
091	370126	SCREWCAP M8X16	2
116	370402	RETAINER CAP	4
117	370403	ROLLER CAGE BEARING	2
118	370426	LOCKING LEVER	1
119	370427	PLASTIC KNOB 10	1
120	370123	WASHER WAVE M8	1
121	370428	NUT M5	2
122	370429	SCREWCAP M5x14	1
123	370262	SPRING CABLE RETURN	1
124	370430	SCREWCAP M5x20	1
125	370136	NUT M8 H5	2
126	370431	HEIGHT ADJUST ASSY	1

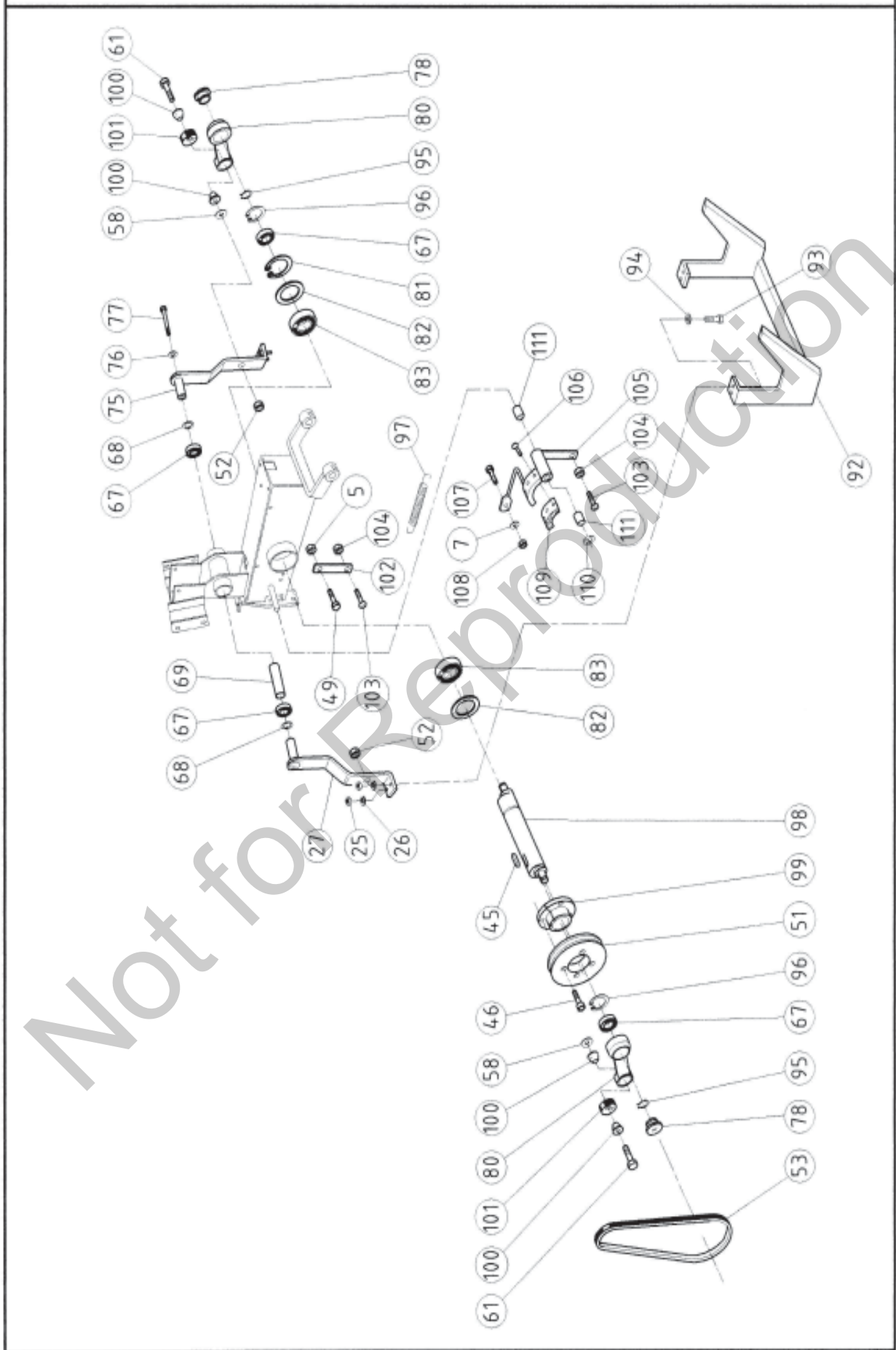

PART LIST

3/6

005	370107	NUT LOCK M6 H6	1
007	370112	WASHER FLAT M6	1
025	370136	NUT M8 H5	4
026	370407	WASHER GROWER U 1751 8	4
027	370501	ARM CONTROL BLADE (RIGHT)	1
045	370157	KEY 8X7X25	1
046	370177	SCREW ALLEN M6 X 25	4
049	370128	SCREWCAP M6X14	1
051	370211	PULLEY FOR SHAFT WITH ECCENTRICS	1
052	370150	NUT M12	2
053	370197	BELT SHORT XDV48/290	1
058	370124	WASHER FLAT M12X24	2
061	370287	SCREW SPECIAL	2
067	370138	BEARING 17X40X12 6203-2RS	4
068	370135	SHIM ADJUSTMENT 17X24X0.5	2
069	370232	BUSHING	1
075	370502	ARM CONTROL BLADE (LEFT)	1
076	370120	WASHER SPLIT M6	1
077	370154	SCREWCAP M6X85 P.F.	1
078	370286	COVER PLASTIC CONNECTING ROD	2
080	370217	ROD CONNECTING	2
081	370155	RING SNAP INTERNAL E35	1
082	370156	SHIM ADJUSTMENT 35X45X0.5	2
083	370137	BEARING 35X62X14 6007-2RS	2
092	370279	BLADE CUTTING	1
093	370408	SCREW M8X26	4
094	370123	WASHER WAVE M8	4
095	370122	RING SNAP INTERNAL E17	2
096	370166	RING SNAP INTERNAL 140	2
097	370309	SPRING	1
098	370216	SHAFT WITH ECCENTRICS	1
099	370212	PULLEY LOCKING HUB	1
100	370231	SEMI-CONE	4
101	370261	PAD RUBBER	2
102	370298	SPRING HOOK	1
103	370299	SCREW BUTTON M6 X 16	2
104	370297	NUT M6 H4	2
105	370300	BRAKE	1
106	370301	SCREWCAP M4 X 14	3
107	370302	CLAMP 7 X 20	1
108	370127	NUT M6	1
109	370303	PAD BRAKE	1
110	370173	RING RADIAL ELASTIC D 10	1
111	370304	BUSHING SELF LOCK	2

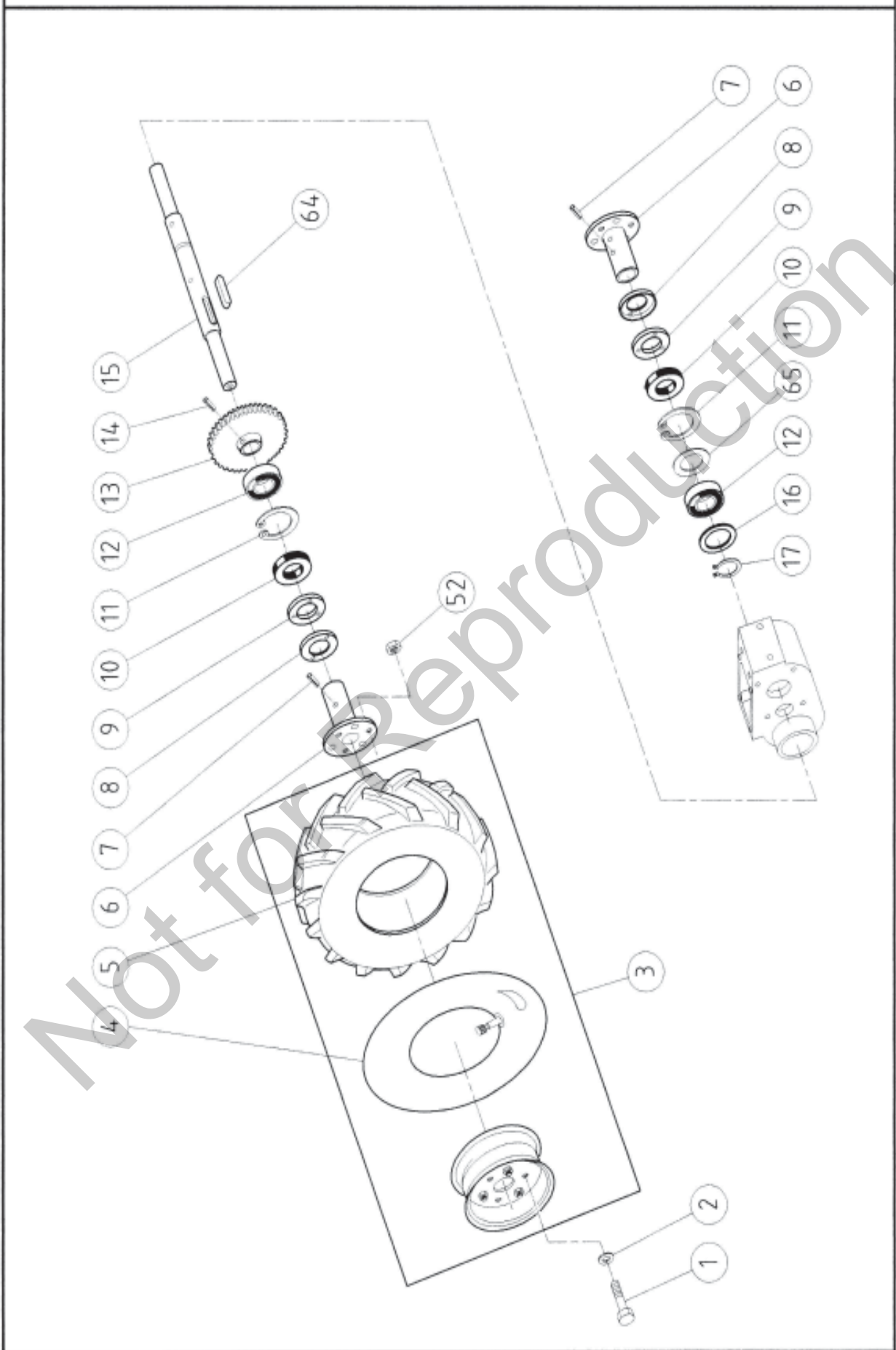

PART LIST

4/6

001	370126	SCREWCAP M8X16	6
002	370110	WASHER FLAT M8	6
003	370194	REAR WHEEL 3.00-4 TRACTOR	2
004	370277	TIBE INNER REAR WHEEL	2
005	370409	TIRE 3.00-4 TRACTOR	2
006	370195	HUB WHEEL	2
007	370158	PIN ELASTIC 10X40	2
008	370288	COVER DUST	2
009	370289	FELT PROTECTION	2
010	370305	RING SEAL 25 X 52 X 7	2
011	370114	RING SNAP INTERNAL 152	2
012	370131	BEARING 25X52X15 6205	2
013	370199	GEAR REDUCTION-CROWN	1
014	370180	DOWEL M8X14	1
015	370196	AXLE REAR	1
016	370142	SHIM ADJUSTMENT 25X35X1	1
017	370290	SEEGER E25	1
052	370136	NUT M8 H5	6
064	370170	KEY 7X8X35	1
065	370121	SHIM ADJUSTMENT Ø 42X52X0.5	1

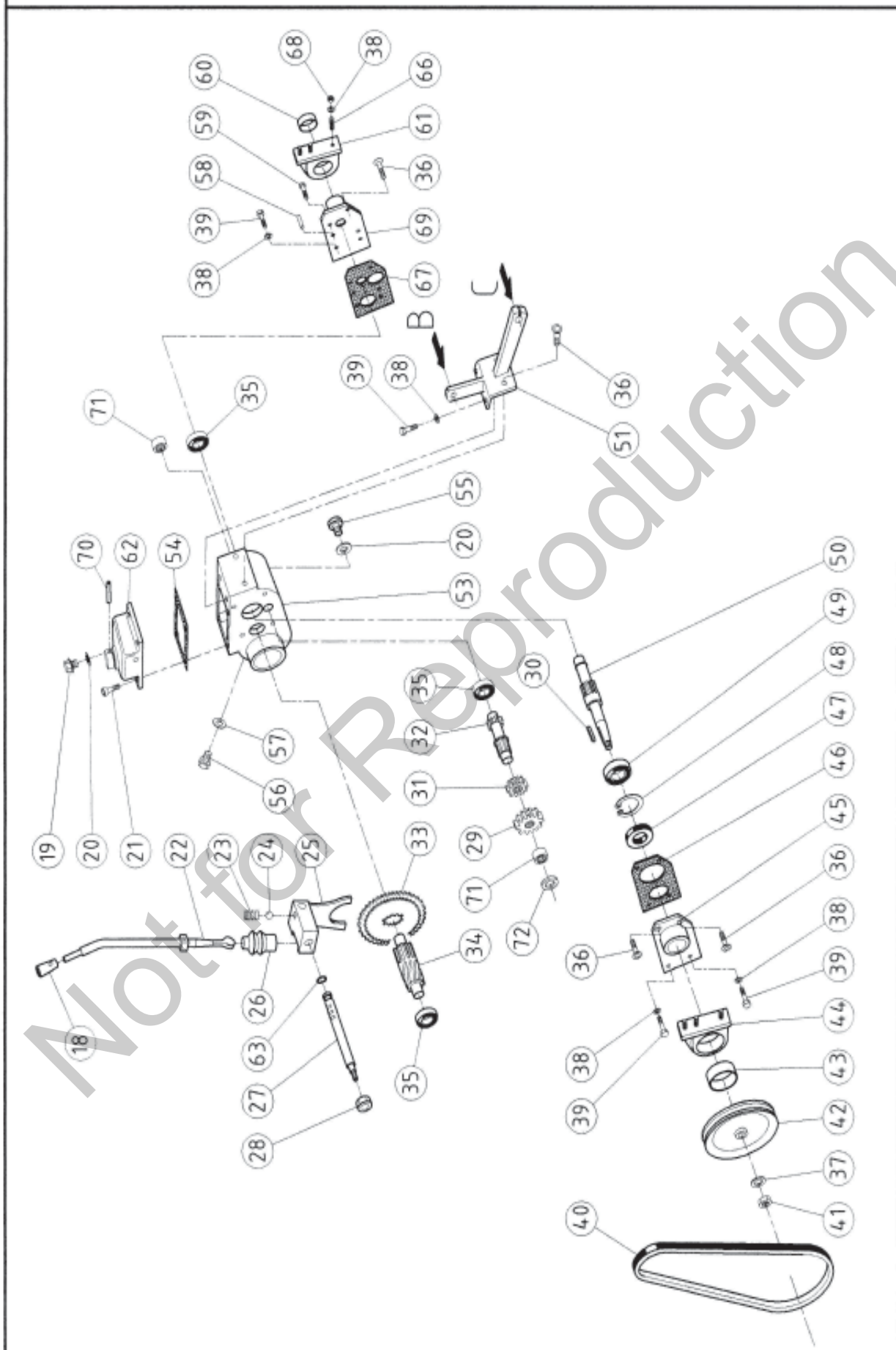

018	370182	PLASTIC KNOB Ø 12	1
019	370162	CAP PLASTIC	1
020	370163	WASHER FIBER	1
021	370159	SCREW ALLEN M 8 X 16	4
022	370226	LEVER ENGAGE-DISENGAGE	1
023	370264	SPRING GEAR FORK 6X25	1
024	370160	BALL	1
025	370410	FORK 1st-2nd	1
026	370161	CASING	1
027	370411	PIN FORK	1
028	370125	NUT LOCK M8	1
029	370412	GEAR Z8	1
030	370164	KEY 5X5X18	1
031	370413	GEAR 2nd SPEED	1
032	370414	PINION	1
033	370415	GEAR 1st and 2nd SPEED	1
034	370416	PINION REDUCING GEAR	1
035	370133	BEARING 15X35X11 6202-2RS	3
036	370104	SCREWCAP M8X18	4
037	370124	WASHER FLAT M12X24	1
038	370123	WASHER WAVE M8	12
039	370130	SCREWCAP M8X20	6
040	370198	BELT BIG 48-430 L443	1
041	370150	NUT M12	1
042	370213	PULLEY CAST IRON PRIM. Ø =150 mm.	1
043	370141	BUSHING SELF-LUBRICATING	1
044	370209	SUPPORT BOX (RIGHTHAND)	1
045	370417	RIGHT COVER	1
046	370418	GASKET RIGHT COVER	1
047	370168	O-RING 17X40X7	1
048	370166	RING SNAP INTERNAL 140	1
049	370179	BEARING 17x40x16 62203	1
050	370419	PRIMARY PINION	1
051	370245	SUPPORT TIE ROD	1
053	370420	GEAR BOX	1
054	370242	GASKET COVER	1
055	370190	CAP METAL	1
056	370183	VTCE BUTTON M6X08	1
057	370185	WASHER FIBER M6X10	1
058	370167	PIN CYLINDRICAL 8X18	2
059	370109	SCREW BUTTON HEAD M8X16	1
060	370140	BUSHING SELF-LUBRICATING PCM 252820 B	1
061	370210	SUPPORT BOX (LEFTHAND)	1
062	370208	COVER BOX	1
063	370171	O-RING 108 (8.73 X1.78)	1
066	370291	SCREW STUD M8 UNI 5911	6
067	370421	GASKET LEFT COVER	1
068	370102	NUT 8 H 6.5	6
069	370422	LEFT COVER	1
070	370169	PIN CYLINDRICAL 6X35	1
071	370423	ROLLER CAGE BEARING HK 1412	2

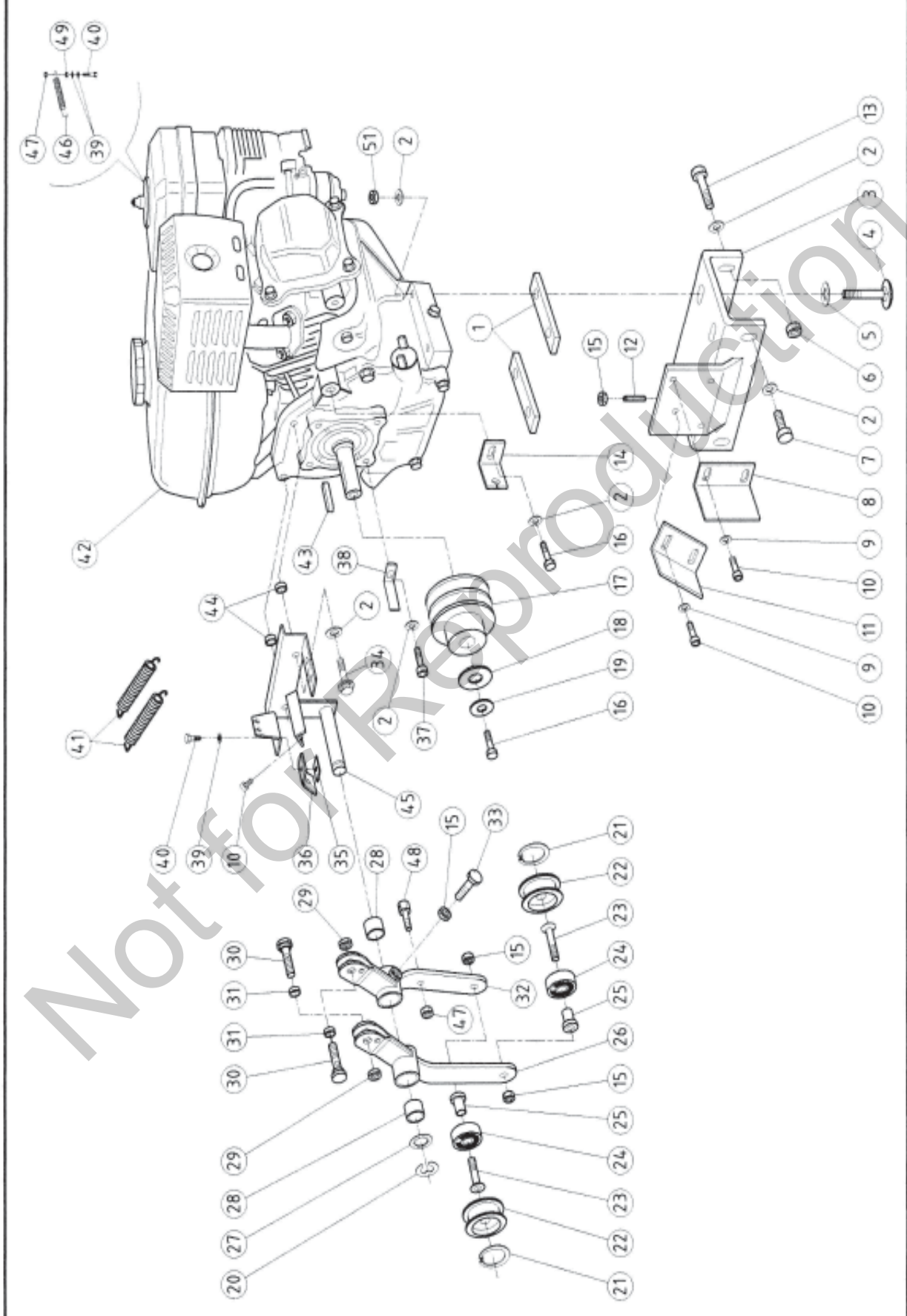

PART LIST

6/6

001	370193	SHIM ENGINE 20X6	2
002	370110	WASHER FLAT M8	8
003	370234	SUPPORT ENGINE	1
004	370172	SCREW TTQST 8X40	4
005	370175	WASHER TOROIDAL M24	4
006	370125	NUT LOCK M8	2
007	370126	SCREWCAP M8X16	2
008	370238	GUIDE BELT No.1	1
009	370113	WASHER FLAT M5	4
010	370106	SCREW ALLEN M5X8	5
011	370237	GUIDE BELT	1
012	370176	DOWEL M8X35	1
013	370130	SCREWCAP M8X20	2
014	370266	BRACKET GUARD SUPPORT	1
015	370136	NUT M8 H5	4
016	370181	SCREW 5/16 X3/4 mm 19	2
017	370214	PULLEY ENGINE SECT. H	1
018	370119	WASHER FLAT M8X32	1
019	370123	WASHER WAVE M8	1
020	370173	RING RADIAL ELASTIC D 10	1
021	370117	RING SNAP INTERNAL 132	2
022	370219	ROLL TIGHTENING	2
023	370103	SCREWCAP M8X25	2
024	370116	BEARING 12X32X10 6201 2RS	2
025	370221	BUSHING BEARING	2
026	370223	TENSIONER BELT	1
027	370101	SHIM ADJUSTMENT 12.2X24X0.8	1
028	370115	BUSHING SELF-LUBRICATING	2
029	370127	NUT M6	2
030	370220	CLAMP	2
031	370188	CLAMP SPACER	2
032	370246	TENSIONER BELT THREADED	1
033	370273	SCREW TENSIONER	1
034	370306	SCREWCAP M8X40	2
035	370270	NUT SPECIAL	1
036	370265	BRACKET GUARD FIXING	1
037	370184	SCREWCAP 5/16-24 X 5/8	1
038	370192	BRACKET FRONT 15X3	1
039	370112	WASHER FLAT M6	2
040	370128	SCREWCAP M6X14	2
041	370262	SPRING CABLE RETURN	2
042	600115	ENGINE HONDA 5.5 GX160K1QX2	1
043	370174	KEY 4.8X4.8X32	1
044	370222	SPACER	2
045	370225	SUPPORT TIGHTENER	1
046	370263	SPRING ACCELERATOR RETURN	1
047	370107	NUT LOCK M6 H6	2
048	370307	DRUM WIRE HOLDER	1
049	370297	NUT M6 H4	1
050	370102	NUT 8 H 6.5	4