



MV PUSH Owner's Manual



Push Multi-Vac Owner's Manual

MV650H

Beginning Serial #: 020516001

Accessories

CASTER KIT	HOSE KIT	BAG LINER KIT	FELT BAG KIT	LINER KIT
Use on hard surface for maneuverability.	For vacuuming hard to reach areas.	To collect leaves, thatch, and grass.	Use on all dusty conditions.	Interior housing liner to decrease housing wear.
P/N 840129	P/N 840116	P/N 840134	P/N 840194	P/N 840201

Original Instructions

IMPORTANT- READ CAREFULLY BEFORE USE AND KEEP FOR FUTURE REFERENCE.



MV PUSH Owner's Manual

CONTENTS

SPECIFICATIONS	3
INSTRUCTION LABELS	4
ASSEMBLY INSTRUCTIONS	5-8
OPERATION	9-11
MAINTENANCE AND TROUBLESHOOTING	11-13
ILLUSTRATED PARTS LIST	14-20

Go to <http://www.billygoat.com> for French-Canadian translations of the product manuals.

Visitez <http://www.billygoat.com> pour la version canadienne-française des manuels de produits



MV PUSH Owner's Manual

SPECIFICATIONS

	MV650
Engine Type	Honda GSV190LN1L
Horsepower	6.5 (4.85 kW)
Fuel Capacity	1.6 qt (1.5 L)
Oil Capacity	0.69 qt (0.65L)
Engine Weight	28 lbs (12.7 kg)
Unit Weight	157 lbs (71.2 kg)
Shipping Weight	180 lbs (81.7 kg)
Overall Dimensions	28" Wide x 62.5" Long x 45.5" High
Maximum Operating Slope	20°

SAFETY



WARNING



This product can expose you to chemicals including gasoline engine exhaust, which is known to the State of California to cause cancer, and carbon monoxide, which is known to the State of California to cause birth defects or other reproductive harm. For more information go to www.P65Warnings.ca.gov.



MV PUSH Owner's Manual

INSTRUCTION LABELS

The labels shown below were installed on your BILLY GOAT® MV Vacuum. If any labels are damaged or missing, replace them before operating this equipment. For your convenience in ordering replacement labels, part numbers are included in the Illustrated Parts List. The correct position for each label may be determined by referring to the Figure and Item numbers shown.



LABEL FUEL WARNING
ITEM 55 P/N 400268



LABEL EAR EYE BREATHE READ
ITEM 162 P/N 100346

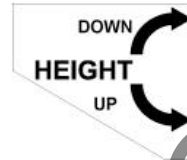

LABEL HEIGHT ADJUST
ITEM 34 P/N 840054



LABEL DANGER
ITEM 11 P/N 400424



LABEL DANGER
ITEM 174 P/N 810736



LABEL DOOR OPENING
ITEM 175 P/N 840080

ENGINE LABELS



CONTROLS



ITEM 57 P/N 840045



ASSEMBLY INSTRUCTIONS

Your BILLY GOAT® MV Vacuum was shipped in one carton, completely assembled except for the Hood/Upper Handle Assembly. Mounting hardware for the Hood/Upper Handle Assembly is temporarily installed on the lower handle and the Housing Assembly.



READ all safety instructions before assembling unit.

TAKE CAUTION when removing the unit from the box. The Hood/Upper Handle Assembly is attached to the unit by cables.

PARTS BAG & LITERATURE ASSY

Warranty card P/N- 400972, Owner's Manual P/N-840244, General Safety and Warnings Manual P/N-100294, Declaration of Conformity P/N-840204



DISCONNECT spark plug wire before assembling unit.

Boxing Parts Checklist

- Honda 6.5 Engine
- Parts bag P/N-840190
- Ty-wraps (2 ea)

ASSEMBLY

1. Attach hood assembly to the housing then hold in place during step 2.
NOTE: Be sure all cables are routed on the underside of the hood and housing. (See Fig. 1)
2. Install (item 170) center bolt first when aligned with a nut on the housing. (See Fig. 2)
3. Attach rest of hood assembly to the housing using corresponding hardware. *NOTE:* You will have to insert the bolt/washer from the inside by reaching through the hood. (See Fig. 2)
4. Attach upper handle brace to lower handle using corresponding hardware. Then repeat this step on the other side. (See Fig. 3 next page)
5. Attach rod end (item 164) to the nozzle door rod then secure in place by tightening jam nut. (See Fig. 4 next page)
6. Attach nozzle door rod to the nozzle door using corresponding hardware. *NOTE:* It is easier to do this with nozzle door closed.
7. Attach rod end to rod (See Fig. 5 next page).
8. Attach nozzle door rod to the lever with nozzle door closed and lever in hose kit position. *NOTE:* Check to see that the nozzle door opens and closes all the way (see page 15). Tighten or loosen the rod end (item 164) for any adjustments. (See Fig. 4 and 5)
9. Install cable ty wraps. (See Fig. 6 next page)
10. Reconnect spark plug wire.
11. Attach the bag. (See Fig. 7 next page)

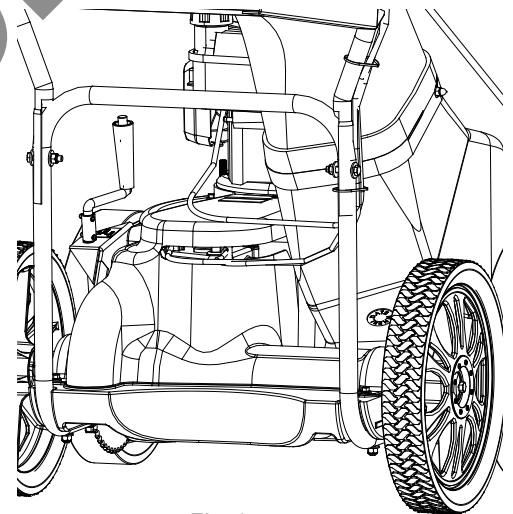

Fig. 1

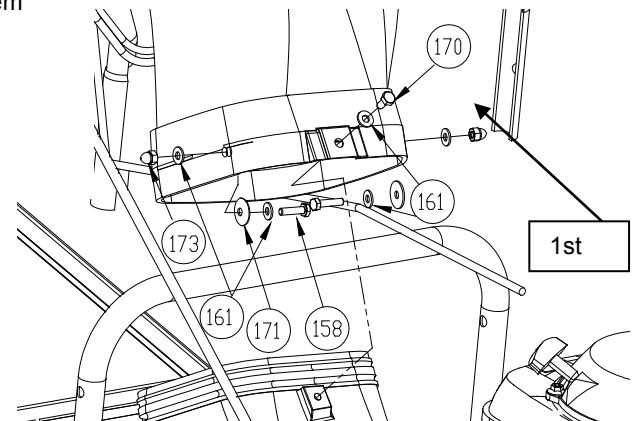

Fig. 2



MV PUSH Owner's Manual

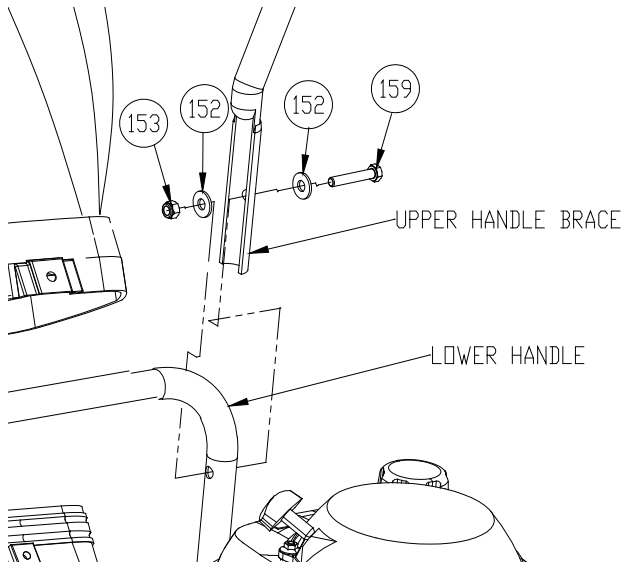

Fig. 3

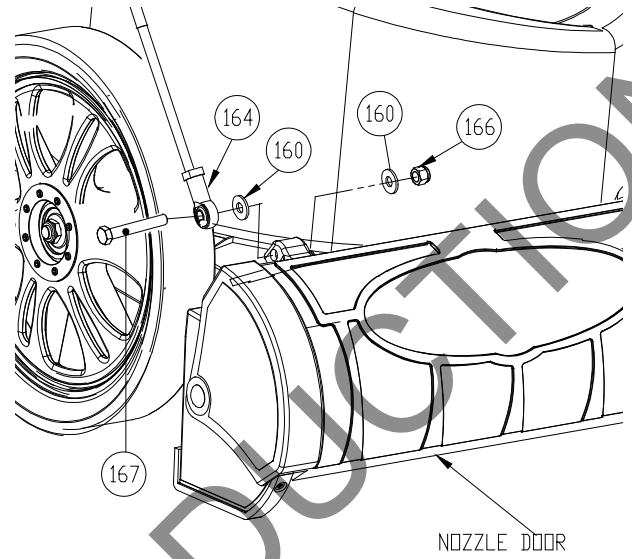

Fig. 4

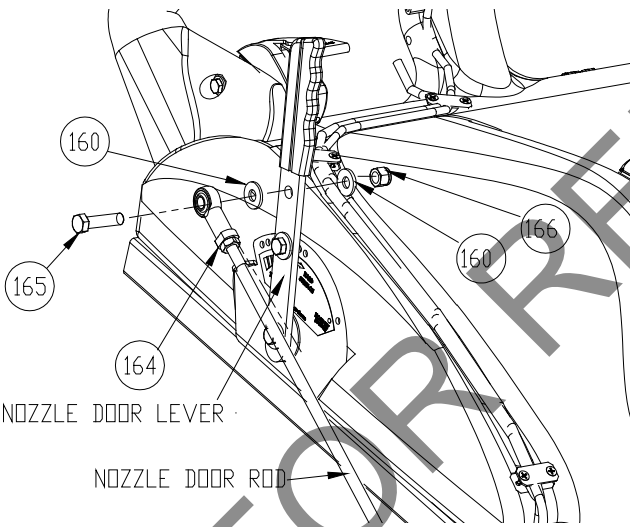

Fig. 5

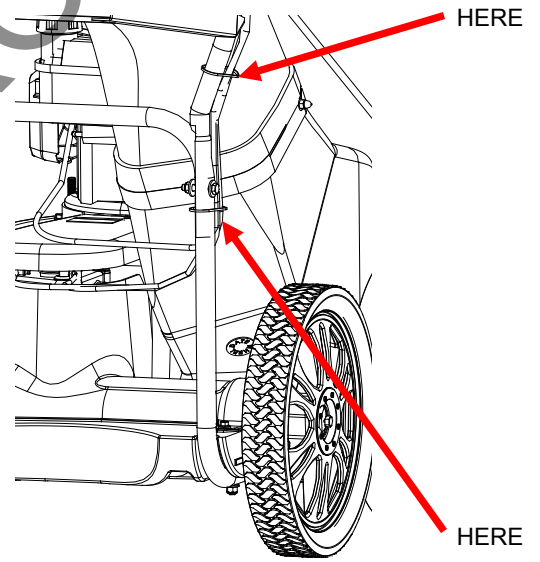

Fig. 6

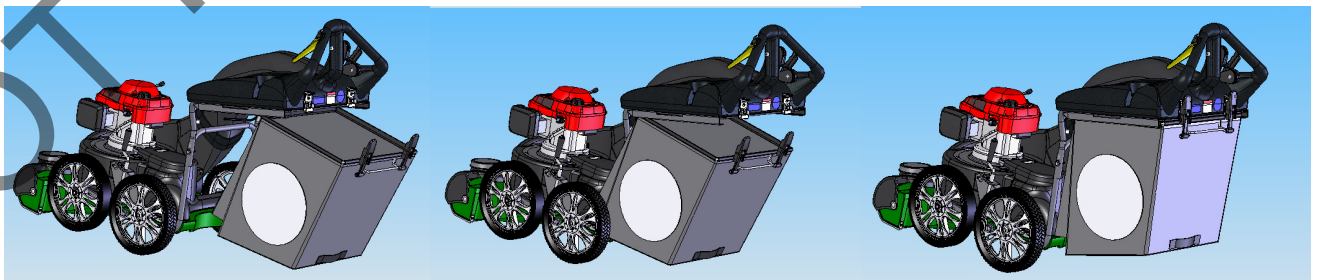
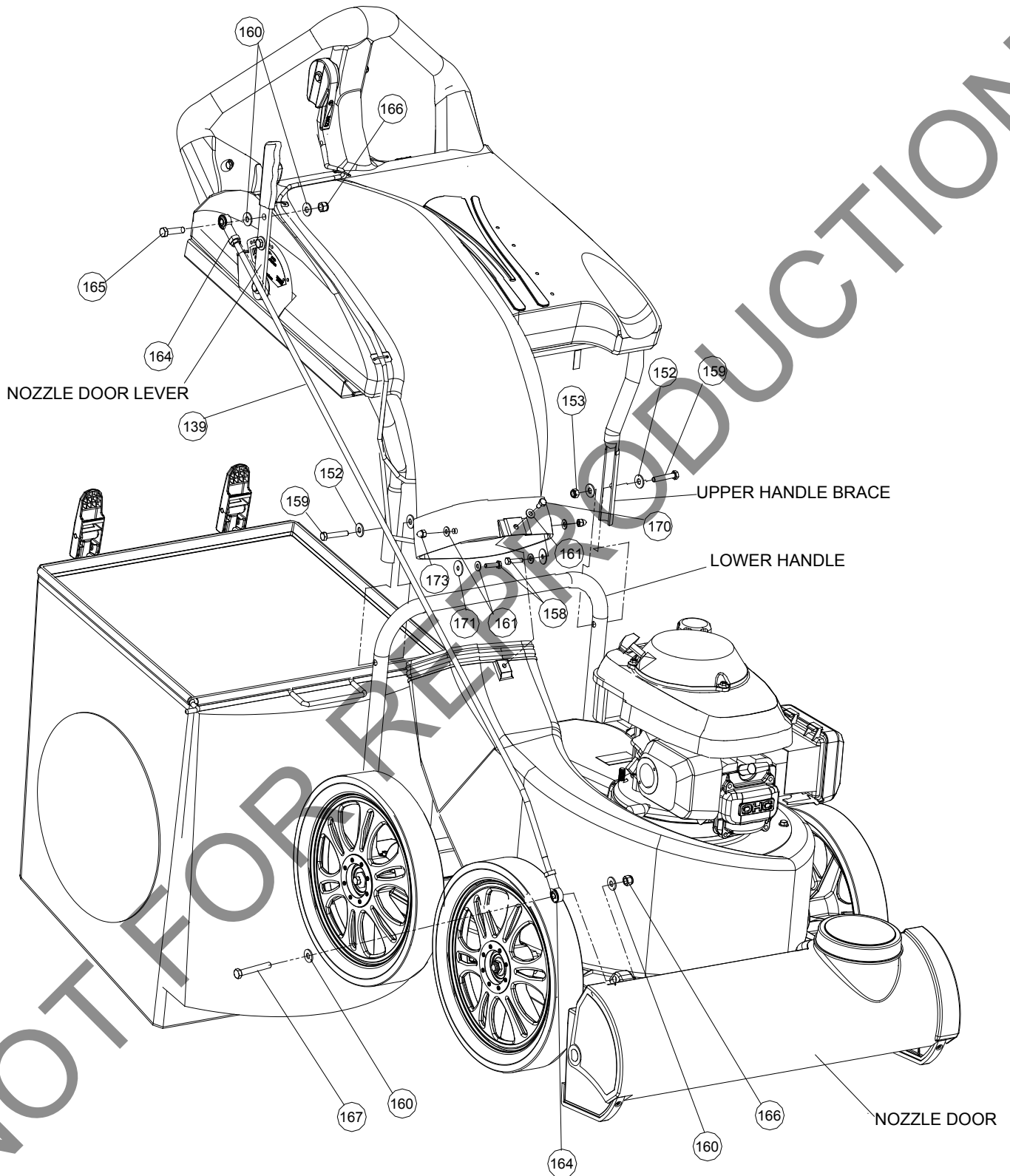

Fig. 7



MV PUSH Owner's Manual



MV Vacuum Assembly Drawing



PARTS BAG PARTS LIST

ITEM NO.	PART NO.	DESCRIPTION	QTY
139	840061	ROD LIFT NOZZLE DOOR	1
150	900407	TY- WRAP	2
152	8171003	WASHER 5/16" FLAT ZP	4
153	8160002	NUT LOCK 5/16"-18	2
158	8041006	SCREWCAP 1/4"-20 X 1" ZP	2
159	8041031	SCREWCAP 5/16" X 1 3/4" ZP	2
160	8171004	WASHER 3/8 FLAT	4
161	8172007	WASHER 1/4" SAE ZP	5
164	400886	ROD END BALL JOINT 3/8" NF	2
165	8041052	SCREWCAP 3/8"-16 X 1 1/2" ZP	1
166	8160003	NUT LOCK 3/8"-16	2
167	8041056	SCREWCAP 3/8"-16 X 2 1/2" ZP	1
170	8041004	SCREWCAP 1/4"-20 X 3/4" HCS ZP	1
171	8172019	WASHER FENDER 1/4" ZP	2
173	840071	NUT ACORN 1/4"-20	2



OPERATION

OPERATOR CONTROLS

The operator's position is at the rear of the machine between the handlebars. The operator should STAND in a position to allow both handlebars to be grasped firmly, which allows sufficient leverage to steer the machine. Operator's controls are shown below.

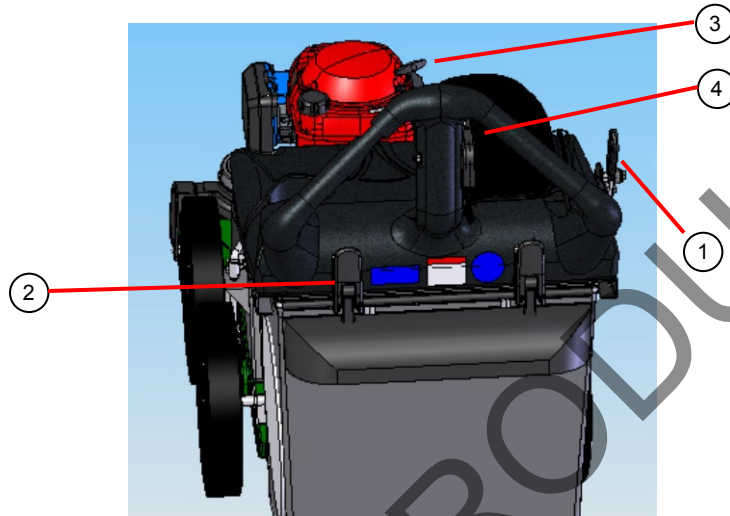

Operator Control Locations

- | | | | |
|---|----------------------|---|------------------|
| 1 | Nozzle Door Adjuster | 4 | Throttle Control |
| 2 | Bag Latch | | |
| 3 | Pull Starter | | |

STARTING



CHECK engine oil level before operating machine.

DO NOT START the equipment without the debris bag in place.

1. Place equipment on a level, firm surface that is free of rocks or other debris.
2. Place throttle in CHOKE position.
3. Secure the unit with left hand at the handle then pull starter rope with right hand to start engine. *NOTE:* Pull starter cord slowly until resistance is felt. Then pull cord rapidly to avoid kickback.
4. Move throttle control back to RUN position and allow engine to reach correct operating speed.

SHUT DOWN

1. Pull the throttle control all the way back to the STOP position.

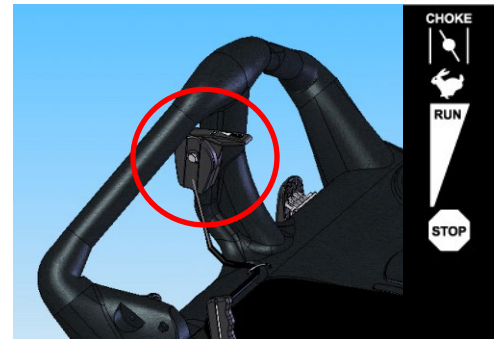

Fig. 8

Secure unit at the handle with left hand during start.

Pull rope starter with right hand.

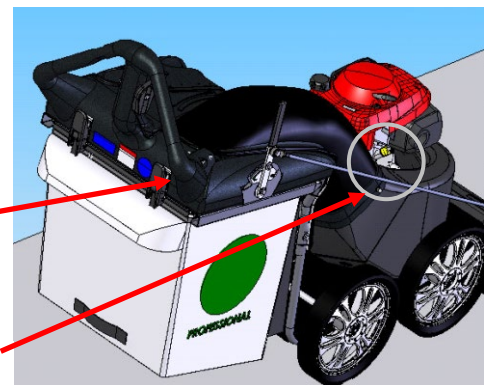

Fig. 9



MV PUSH Owner's Manual

VACUUM NOZZLE HEIGHT ADJUST

For maximum pickup: Adjust nozzle height as close to debris as possible, but without blocking airflow into the nozzle. **NOTE:** Never bury nozzle into debris. The vacuum nozzle is raised and lowered by turning the crank handle clockwise and counter-clockwise. (See Fig. 10)

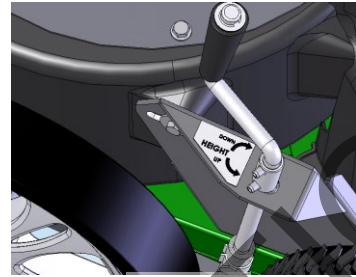

Fig. 10

VACUUM NOZZLE DOOR ADJUSTMENT

The vacuum nozzle door adjusts for the maximum performance under various applications.

- With the handle fully back the nozzle is fully opened. This is ideal for turf application. (See Fig. 11)
- For hard surface applications, set the handle midway. (See Fig. 12)
- Close nozzle for use with the Optional Hose Kit (P/N 840116). This adjustment is ideal to use with the Hose Kit. (See Fig. 13)



Fig. 11

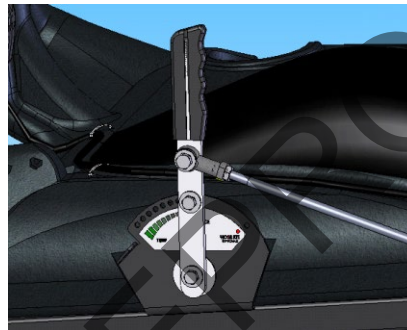

Fig. 12



Fig. 13

VACUUMING OPERATION

This machine is designed for vacuuming leaves, grass clippings, and other types of organic litter. Debris mixed with cans, bottles, and small amounts of sand can be vacuumed; however, it is not this machine's primary purpose. Vacuuming cans, bottles, and sand will affect the longevity of your machine. In dusty conditions it may be necessary to purchase Felt Bag Kit (P/N 840022).

Do not operate if excessive vibration occurs. If excessive vibration occurs, shut engine off immediately and check for damaged or worn impeller, loose impeller bolt, loose impeller key, loose engine or lodged foreign objects. Note: See parts list for proper impeller bolt torque specifications. (See Trouble Shooting section on page 22).

CLEARING A CLOGGED NOZZLE



DISCONNECT spark plug wire before servicing unit.

1. Shut engine off and wait for impeller to stop completely.
2. Disconnect spark plug wire.
3. Wearing durable gloves, remove clog. Caution: clog may contain sharp materials.
4. Reconnect spark plug wire.



MV PUSH Owner's Manual

DEBRIS BAG

Debris bags are normal replaceable wear items.

Bag liners are available for use in various conditions where debris will be vacuumed. (See Bag Liner Accessories on page 1).

DO NOT place bag on or near hot surface, such as engine.

Be sure engine has come to a complete stop before removing or emptying bag!

*****TIPS*****

Frequently empty debris to prevent bag overloading with more weight than you can lift.

Many vacuums are used where dust is mixed with trash. Your unit can intermittently vacuum in dusty areas. However, following these rules will help maintain your machine's ability to vacuum in dusty conditions:

- Run machine at idle to quarter throttle.
- Machine or pressure-wash debris bag if normal cleaning does not fully clean bag. Bag should be thoroughly dry before use.

Having one or more spare bags (P/N 840189) is a good way to reduce down time while dirty bags are being cleaned.

Felt Bag (P/N 840194) accessory is great when used in dusty conditions.

MAINTENANCE

PERIODIC MAINTENANCE

Periodic maintenance should be performed at the following intervals:

Maintenance Operation	Every Use	Daily or Every 5 Hours	Every 25 Hours
Inspect for worn or damaged parts	•		
Check for excessive vibration		•	
Inspect for loose parts		•	
Clean debris bag	•		
Lubricate throttle control cable and linkage. <i>NOTE: Use white lithium grease or equivalent</i>			•

COMMON REPLACEMENT PARTS

- Bag; P/N 840189 Original Equipment Replacement Bag.
- Skid; P/N 840041 Nozzle Wear Guard Skid.



MV PUSH Owner's Manual

IMPELLER REMOVAL

READ all safety instructions before servicing unit.

DISCONNECT spark plug wire before servicing unit.

1. Wait for engine to cool and disconnect spark plug.
2. Drain fuel and oil from the engine.
3. Remove engine, impeller and mounting plate by removing bolts around outside of housing.
4. Leaving engine fastened to plate, remove impeller bolt and lock washer and slide impeller off crankshaft. (A puller may be required). **CAUTION:** Do not drop impeller.
5. If impeller does not slide off crankshaft, place two crowbars between impeller and housing on opposite sides. Pry impeller away from engine until it loosens. Using a penetrating oil can help loosen a stuck impeller.
6. If the impeller cannot be loosened, obtain a 3/8-24 x 2 3/4" longer bolt of the same diameter and thread type as the impeller bolt. Invert engine and impeller and support engine above ground to prevent recoil damage. Thread longer bolt by hand into the crankshaft until bolt bottoms. Using a suitable gear or wheel puller against the bolt head and the impeller back-plate (near the blades), remove impeller from shaft.
7. To reinstall impeller, use a new impeller bolt and lock washer.
8. Tighten impeller bolt. Torque impeller bolt to 33-38 Ft. Lbs. (45-51 N.m).
9. Reinstall engine, impeller, and mounting plate onto housing in reverse order of removal.
10. Before connecting spark plug wire, slowly pull engine starting rope to insure that impeller rotates freely.
11. Reconnect spark plug wire.

WIRING DIAGRAM

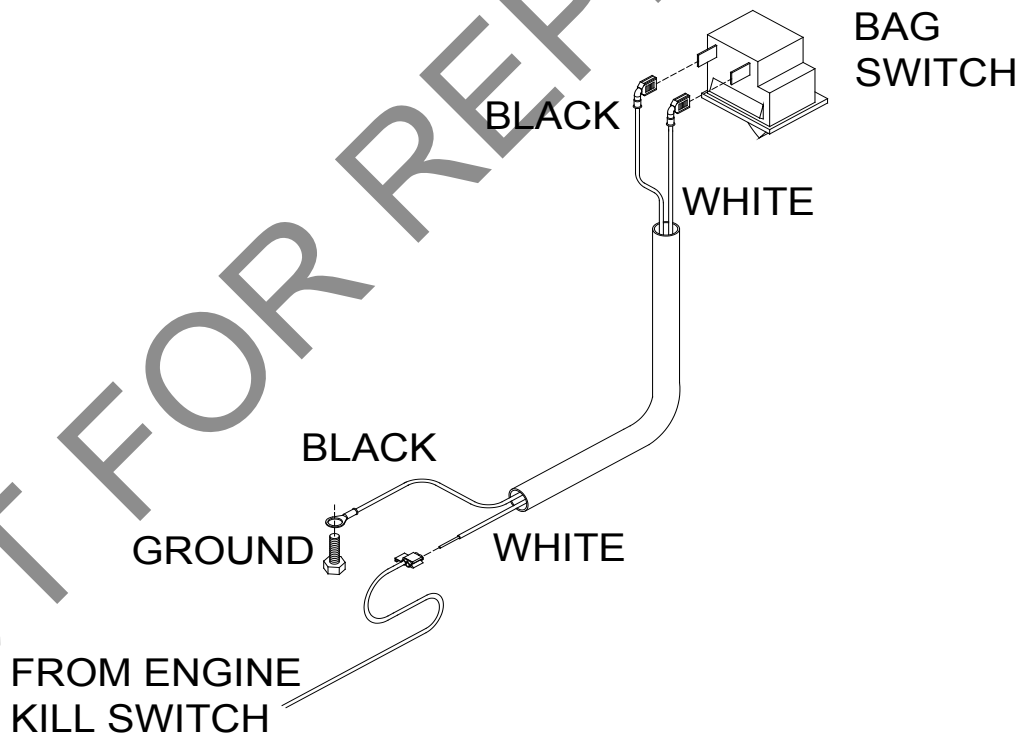

Bag Switch Circuit Schematic Diagram



TROUBLESHOOTING

Problem	Possible Cause	Solution
Will not vacuum or has poor vacuum performance.	Dirty or full debris bag or filter. Nozzle height set too high or too low. Hose kit cap missing. Clogged nozzle or exhaust. Excessive quantity of debris.	Clean debris bag and filter. Shake bag clean or wash. Adjust nozzle height (see page 10). Check for hose kit cap. Unclog nozzle or exhaust (see page 10) Allow air to feed with debris.
Abnormal vibration.	Loose or out of balance impeller. Loose engine.	Check impeller and replace if required. Check engine.
Engine will not start.	Throttle in off position. Engine not in full choke position. Out of gasoline or bad, old gasoline. Spark Plug wire disconnected. Gas valve off. Dirty air cleaner. Safety Interlock disengaged on bag plate.	Check throttle control (see page 9). Check throttle, choke position (see page 9). Check gasoline. Connect spark plug wire. Turn on gas valve. Clean or replace air cleaner. Contact a qualified service person. Latch the bag properly or check the bag rod to see if it's bent.
Engine is locked, will not pull over.	Impeller plugged or clogged. Engine problem.	Remove debris (see page 10). Contact an engine servicing dealer for engine problems.



MV PUSH NOZZLE PARTS DRAWING

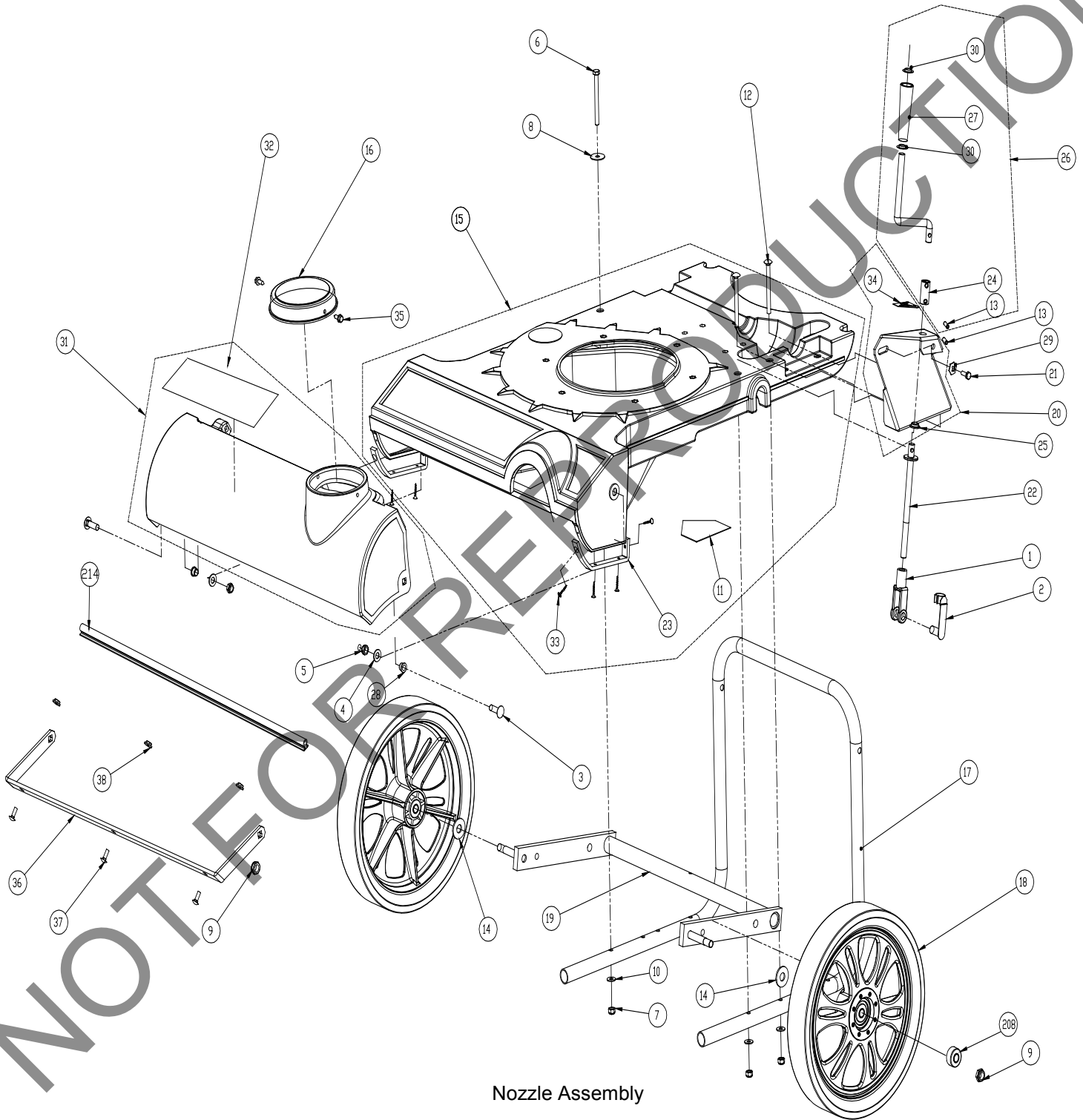



MV PUSH Owner's Manual

MV PUSH NOZZLE PARTS LIST

ITEM NO.	PART NUMBER	DESCRIPTION	MV650H QTY.
1	350127	YOKE 1/2 - 20	1
2	350128	PIN YOKE 1/2"	1
3	840243	SCREWCAP BUTTON HEAD 3/8"-16 X 1 1/4" PL	2
4	8172009	WASHER 3/8" SAE ZP	2
5	8161042	NUT LOCK 3/8-16 LT WT THIN ZP	2
6	8041038	SCREWCAP 5/16 -18 x 3 1/2	1
7	8160002	NYLON INSERT LOCKNUT 5/16-18 UNC	3
8	8172020	WASHER FLAT FENDER 5/16	1
9	8161044	NYLON INSERT LOCKNUT 1/2-13 UNC THIN	2
10	8171002	WASHER 1/4" FC ZP	3
11	400424	LABEL WARNING OPEI	1
12	8024050	BOLTCARRIAGE 5/16-18X3 1/2	2
13	520156	ROLL PIN 1/4 X 1 LONG	2
14	8172011	WASHER 1/2" SAE ZP	2
15	840118	NOZZLE MV VAC ASSEMBLY	1
16	840019	CAP 5 IN HOSE VAC	1
17	840024	HANDLE LOWER MV VAC	1
18	840101	WHEEL 14" ASSEMBLY WITH BEARING AND TIRE	2
19	840104	AXLE FRONT WA MV VAC	1
20	840155	HGT ADJ WA W/LABEL MV VAC	1
21	8041004	SCREWCAP 1/4 - 20 x 0.75 HWH	1
22	840034	LINK HGT ADJ MV VAC	1
23	840041	BRACKET NOZZLE WEAR GUARD MV VAC	2
24	840029	ROD CONNECT HGT ADJ	1
25	840073	BUSHING 0.5" ID 0.625 OD X X 0.250	1
26	840119	ROD HANDLE CRANK ASSEMBLY	1
27	840057	HANDLE CRANK 0.5 ID X 3.72 LONG	1
28	840078	BUSHING 3/8" ID 1/2" OD X 3/8" LONG	2
29	840158	WASHER LOCK 1/4" TWISTED TOOTH	1
30	840207	NUT PAL 0.5" ID X 0.75 OD	2
31	840135	NOZZLE COVER MV VAC	1
32	840259	LABEL MV BADGING	1
33	840035	SCREW PLASTIC	8
34	840054	LABEL HGT ADJ MV VAC	1
35	840082	SCREW PLASTITE 1/4"-10 X 3/4 HWH ZP	2
36	840088	BRACKET NOZZLE COVER REINFORMENT MV	1
37	8024021	BOLT CARRIAGE 1/4-20X0.75	3
38	900455	NUT FLANGE 1/4-20	3
208	840017	MV WHEEL BEARING	2
214	840271	EXTRUSION SEAL DOOR	1



MV PUSH ENGINE PARTS DRAWING

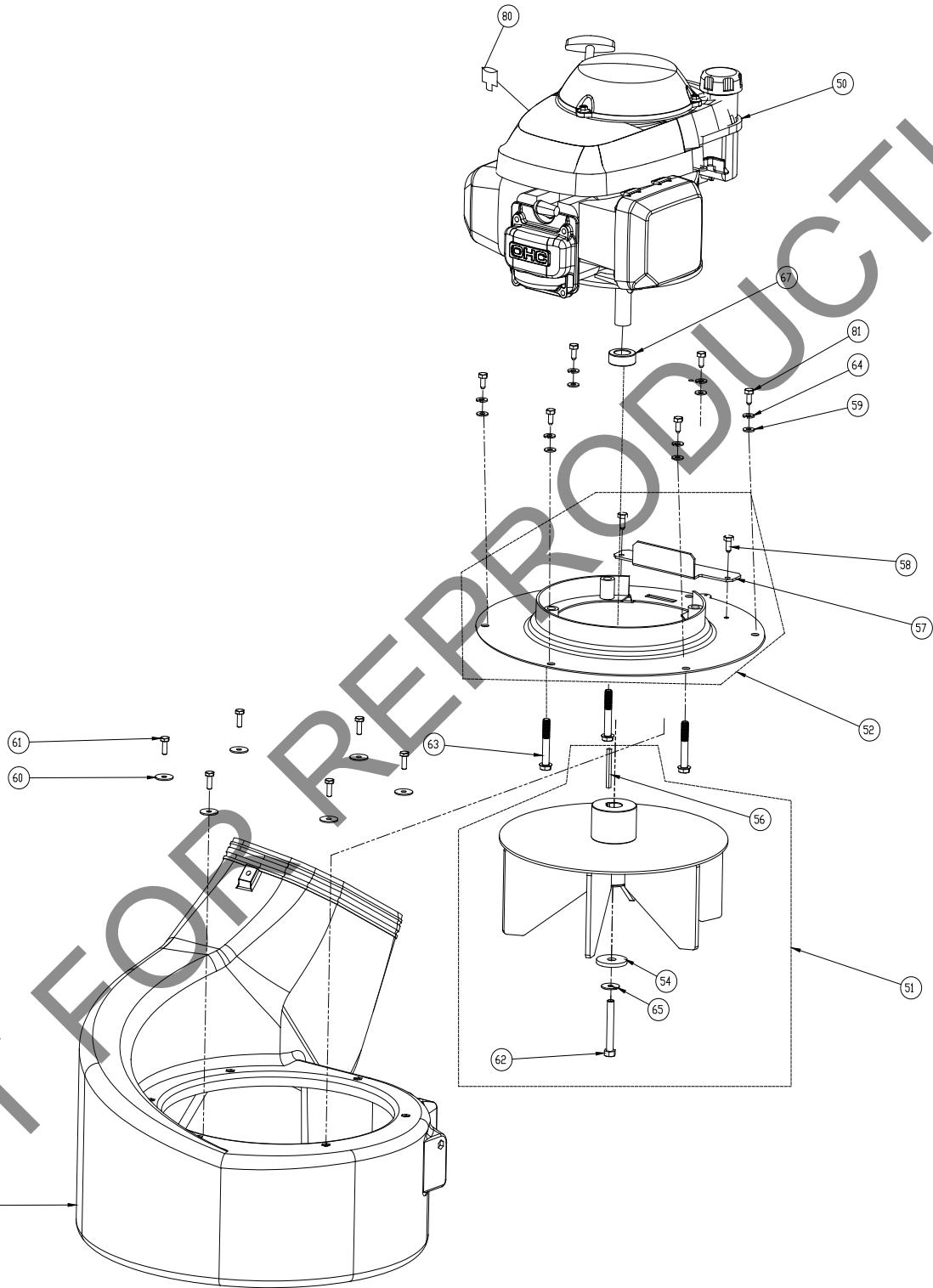

Engine Assembly



MV PUSH Owner's Manual

MV PUSH ENGINE PARTS LIST

ITEM NO.	PART NUMBER	DESCRIPTION	MV650H QTY.
50	840069	ENGINE HONDA 6.5 VERTICAL GSV190	1
51	840100	IMPELLER 12.75 WA SP VAC	1
52	840111-S	PLATE TOP PUSH VAC	1
53	840205	HOUSING PLASTIC VAC	1
54	440153	WASHER 1.5 OD X .453 ID X .25 THK	1
56	9201087	SQ KEY 2.125 X .187	1
57	840220	BRACKET COVER TOP PLATE VAC	1
58	890359	SCREW 1/4"-20 X 5/8" HWH	2
59	8172007	WASHER 1/4" SAE ZP	6
60	8172019	WASHER FENDER 1/4 ZP	6
61	8041004	SCREWCAP 1/4 - 20 x 0.75 HWH	6
62	790167	SCREWCAP 3/8-24X2 3/4" W/PATCH LOCK	1
63	900564	SCREWCAP 3/8"-16X2 1/2" TAPTITE	3
64	8177010	WASHER SPLIT LOCK 1/4"	6
65	8177012	WASHER LOCK 3/8" ST MED	1
67	840083	SPACER 1.50OD X .875ID X .5 THK	1
80	840215	TERMINAL 18-14 BLUE T-TAP	1
81	840213	SCREWCAP 1/4-20X5/8 GR. 5	6



MV PUSH HOOD PARTS DRAWING

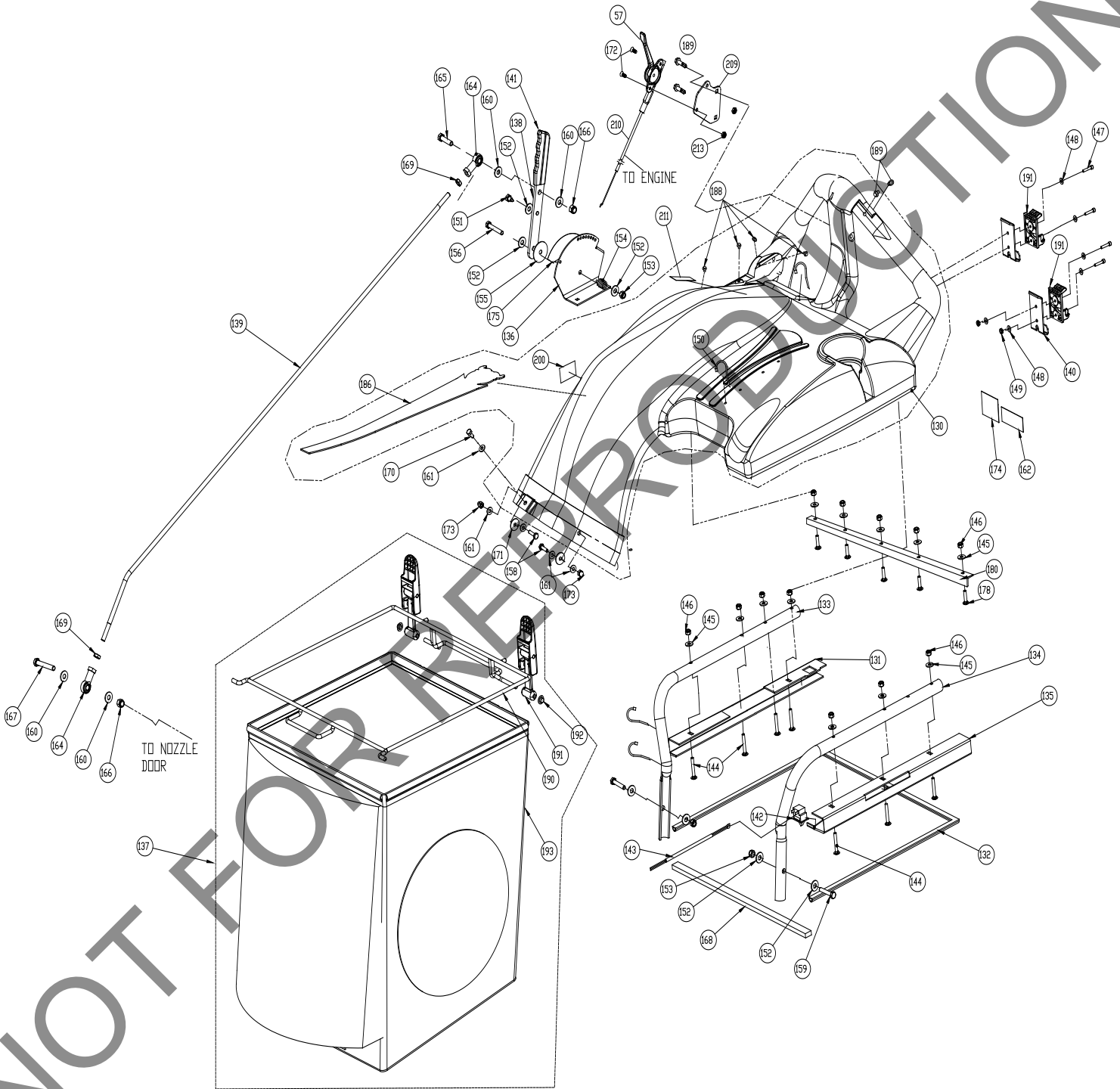

Hood Assembly



MV PUSH Owner's Manual

MV PUSH HOOD PARTS LIST

ITEM NO.	PART NUMBER	DESCRIPTION	MV650H QTY.
57	440013	CONTROL THROTTLE	1
130	840141	HOOD ASSY W/ LABEL MV VAC	1
131	840153	BRACKET BAG CHANNEL RH W/SEAL MV VAC	1
132	840196	SEAL BAG MV VAC	1
133	840037	TUBE HANDLE BRACE RH MV VAC	1
134	840038	TUBE HANDLE BRACE LH MV VAC	1
135	840274	BRACKET BAG CHANNEL LH	1
136	840152	BRACKET NOZZLE DOOR ADJ W/LABEL MV VAC	1
137	840195	BAG ASSEMBLY MV VAC	1
138	840138	BAR LIFT NOZZLE DOOR W/ GRIP MV VAC	1
139	840061	ROD LIFT NOZZLE DOOR SP VAC	1
140	840292	PLATE, BAG LATCH MOUNT	2
141	840191	GRIP LEVER LIFT	1
142	840058	SWITCH INTERLOCK VAC	1
143	840276	HARNESS WIRE ASSY MV VAC	1
144	8024025	BOLT CARRIAGE 1/4-20 X 1.75	7
145	8171002	WASHER 1/4" FC ZP	12
146	8160001	NYLON INSERT LOCKNUT 1/4-20 UNC	12
147	520018	SCREW HEX HEAD #10-24 X 1"	4
148	8172005	WASHER #10 SAE ZP	8
149	8164005	NYLON INSERT LOCKNUT #10-24 UNC	4
150	900407	TY WRAP	1
151	610347	PIN SCREW 1/4-28	1
152	8171003	WASHER 5/16 FLATWASHER Z/P	7
153	8160002	NYLON INSERT LOCKNUT 5/16-18 UNC	3
154	610429	SPRING LEVER GZ	1
155	610348	FIBRE WASHER	1
156	8041032	SCREWCAP 5/16"-18 X2 ZP	1
158	8041006	SCREWCAP 1/4-20X1" ZP	2
159	8041031	SCREWCAP 5/16-18 X 1.75 ZP	2
160	8171004	WASHER 3/8" FC	4
161	8172007	WASHER 1/4" SAE ZP	6
162	100346	LABEL SAFETY PROTECT READ MANUAL	1
164	400886	ROD END BALL JOINT 3/8 NF	2
165	8041052	SCREW CAP 3/8-16X1 1/2 ZP	1
166	8160003	NYLON INSERT LOCKNUT 3/8-16 UNC	2
167	8041056	SCREWCAP 3/8"-16X2 1/2" ZP	1
168	840197	SEAL BAG FRONT HOOD 20.5 LONG	1
169	8149003	NUT REG 3/8-24 NF	2
170	8041004	SCREWCAP 1/4"-20X3/4" HCS ZP	1
171	8172019	WASHER FENDER 1/4 ZP	7
172	830514	SCREW MACH FLAT HD PHIL #10-24	2
173	840071	NUT ACORN 1/4-20	2
174	810736	LABEL DANGER FLYING DEBRIS	1
175	840080	LABEL NOZZLE DOOR MV VAC	1
178	8024021	BOLT CARRIAGE 1/4-20 X 3/4"	5
180	840214	BRACKET HOOD FRONT STRAIGHTENER	1
188	840113	PLUG SNAP RIVET 0.166 DIA	8
189	840114	PLUG SNAP RIVET 0.232 DIA	2
190	840040	ROD BAG WA MV VAC	1
191	840139	LATCH RUBBER ASSEMBLY MV VAC	2
192	360203	PAL NUT 0.312	2
193	840189	BAG DEBRIS MV VAC	1
209	840267	PLATE MV THROTTLE CONTROL	1
210	840268	CABLE THROTTLE CONTROL 52"	1
211	501314	LABEL THROTTLE	1
212	840082	SCREW PLASTITE 1/4"-10 X 3/4" HWH ZP	1
213	8164005	NUT LOCK LT #10-24 HEX	2



MV PUSH REAR AXLE PARTS DRAWING

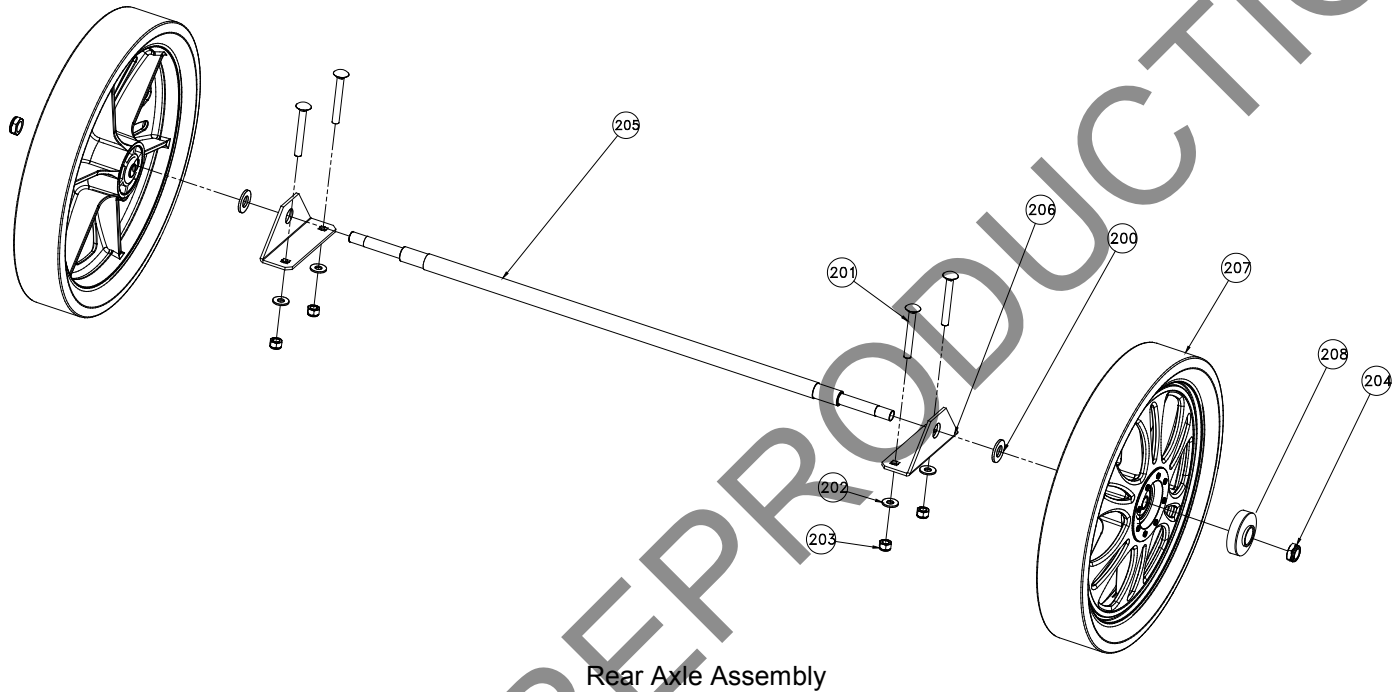

MV PUSH REAR AXLE PARTS LIST

ITEM NO.	PART NUMBER	DESCRIPTION	MV650H QTY.
200	8172011	WASHER FLAT 1/2" SAE	2
201	8024046	BOLT CARRIAGE 5/16-18X2 1/2	4
202	8171002	WASHER 1/4" FC ZP	4
203	8160002	NYLON INSERT LOCKNUT 5/16-18 UNC	4
204	8161044	NYLON INSERT LOCKNUT 1/2-13 UNC THIN	2
205	840091	SHAFT REAR AXLE PUSH VAC	1
206	840090	BRACKET REAR AXLE MOUNT PUSH MV VAC	2
207	840101	WHEEL 14" ASSEMBLY WITH BEARING AND TIRE	2
208	840017	MV WHEEL BEARING	2