



Parts Manual

Mfg. No: 5902011-P2000
P2000, Hurricane Series Ride-On Debris
Blower



5601318 - LED Headlight Kit.....
5109808 - Tire, Debris Blower Pavement Tire 20X8.00-8.....

Not For
Reproduction

Model Components	Page
Blower Group.....	4
Decal Group - Brand and Model.....	6
Decal Group - Safety and Operation.....	8
Deflector Control Group.....	10
Electrical Group.....	12
Electrical Schematic.....	14
Engine Group.....	16
Fuel Tank and Mount Group.....	18
Hydraulic Group.....	20
Instrument Control Panel Group.....	22
Main Frame Group.....	24
Motion Control Group.....	26
Neutral Lock Group.....	28
Operator Area Group.....	30
Parking Brake Group.....	32
Wheel and Tire Group.....	34
Torque Specification Chart.....	36

Not For
Reproduction

Blower Group

Note: Unless noted otherwise, use the standard torque specifications

Mfg. No: 5902011-P2000

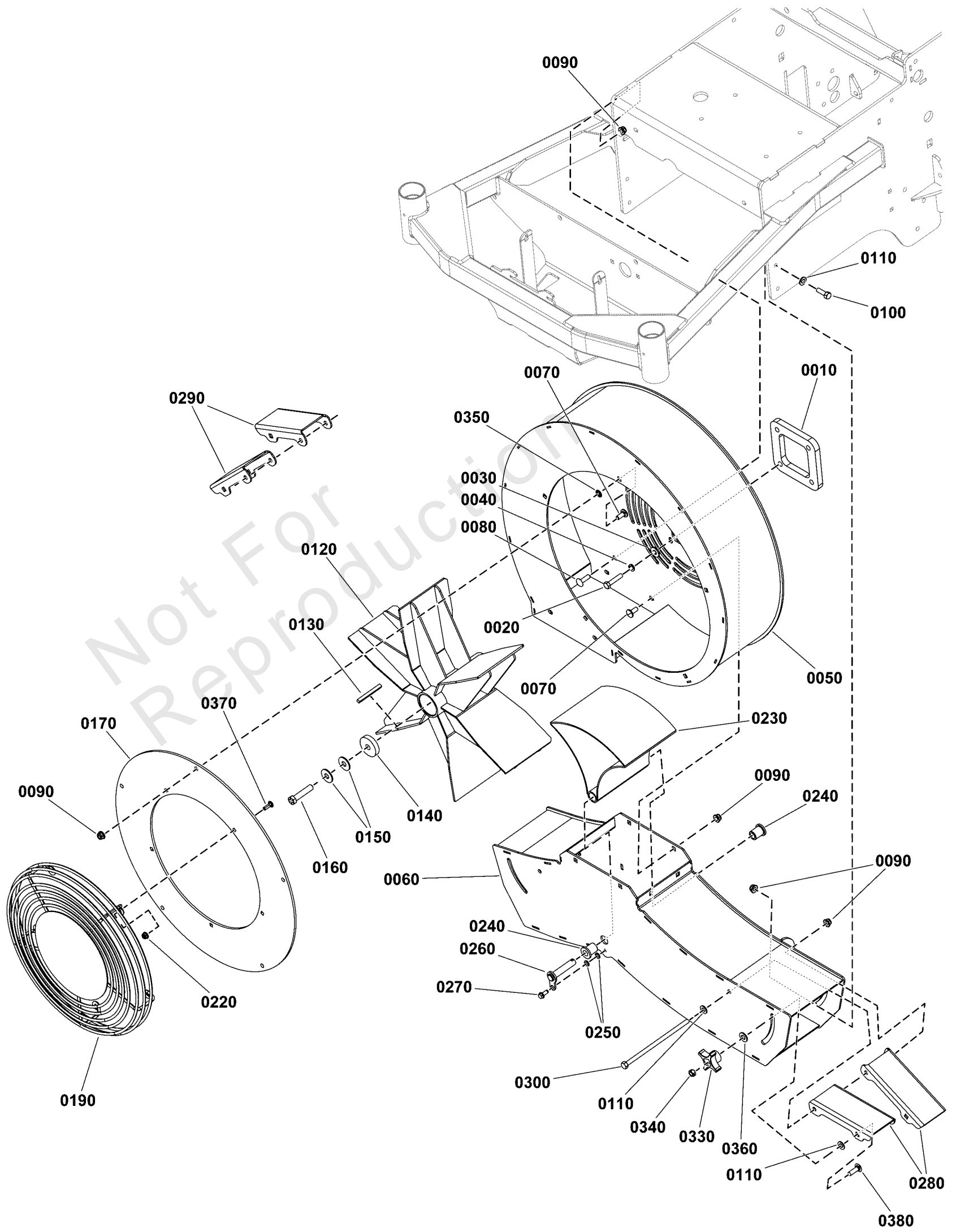

Blower Group

REF NO	PART NO	QTY	DESCRIPTION
0010	5420587AAFS	1	PLATE, SPACER
0020	5025025X12YP	4	BOLT
0030	5025337FS	4	WASHER
0040	5025170SM	4	WASHER, 5/16" LOCK
0050	5420485AD	1	WELD, TOP, BLWR HSG, FB1000 - ORG
0060	5420480AD	1	WELD, BOTTOM, BLWR HSG, FB1000 - ORG
0070	703185	11	BOLT, Round Head, Short Square Neck
0080	703800	6	BOLT, CRRG, 5/16-18X1
0090	703115	19	NUT
0100	5025011X8FS	4	BOLT
0110	703350	14	WASHER
0120	5420582FS	1	IMPELLER
0130	5050407X20SM	1	KEY, 1/4" SQ X 2.50
0140	5106924FS	1	WASHER
0150	5025585YP	2	BELLEVILLE WASHER
0160	5102862FS	1	BOLT, Crankshaft
0170	5420490A	1	PLATE,FRONT COVER, BLWR, FB1000 - BLK
0190	440171AFS	1	GRILLE
0220	5025391FS	5	NUT
0230	5420534AAFS	1	DEFLECTOR
0240	5106943FS	2	BUSHING
0250	5025169FS	2	WASHER
0260	5107337FS	1	PIN
0270	703054	1	SCREW, 1/4-20X0.625
0280	5420595AAFS	2	PLATE
0290	5421429AAFS	2	PLATE
0300	5025011X56	2	BOLT, 5/16-18 x 7
0330	1670578SM	4	KNOB-INT THR .312-18
0340	703164	4	NUT
0350	703297	5	RETAINER, GR5, 5/16
0360	5025698	4	WASHER, 5/16 NYLON, BLK
0370	770135	5	SCREW
0380	703446	4	BOLT, 5/16-18X1.25 G5

Decal Group - Brand and Model

Note: Unless noted otherwise, use the standard torque specifications

Mfg. No: 5902011-P2000

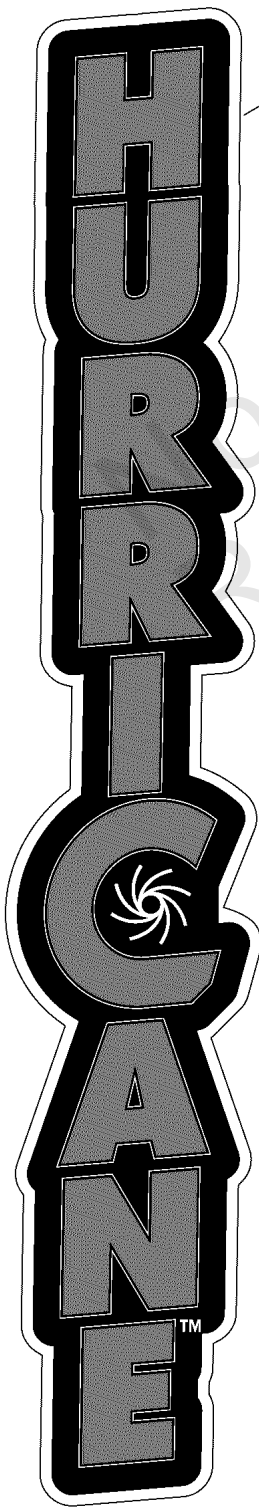
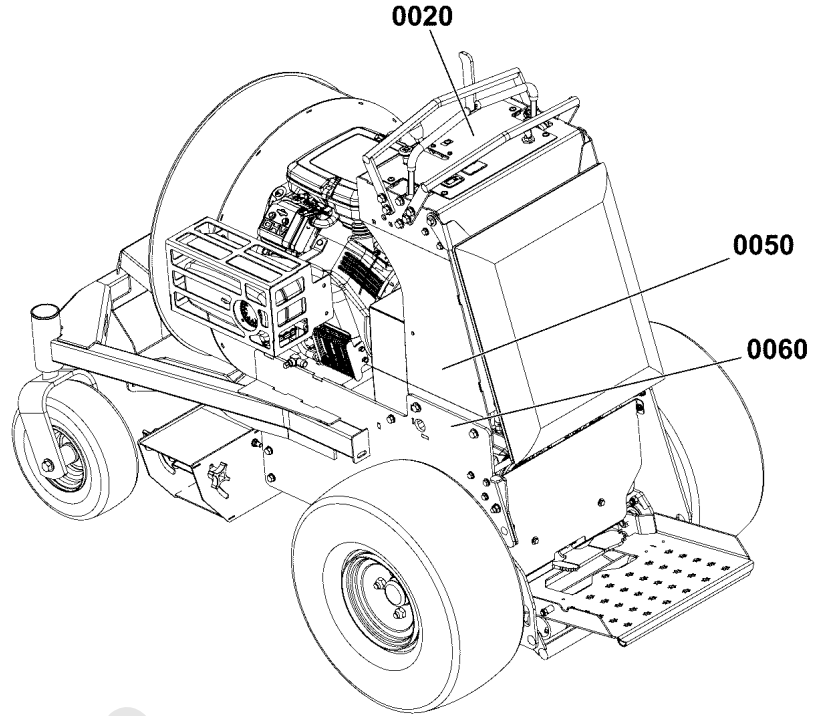
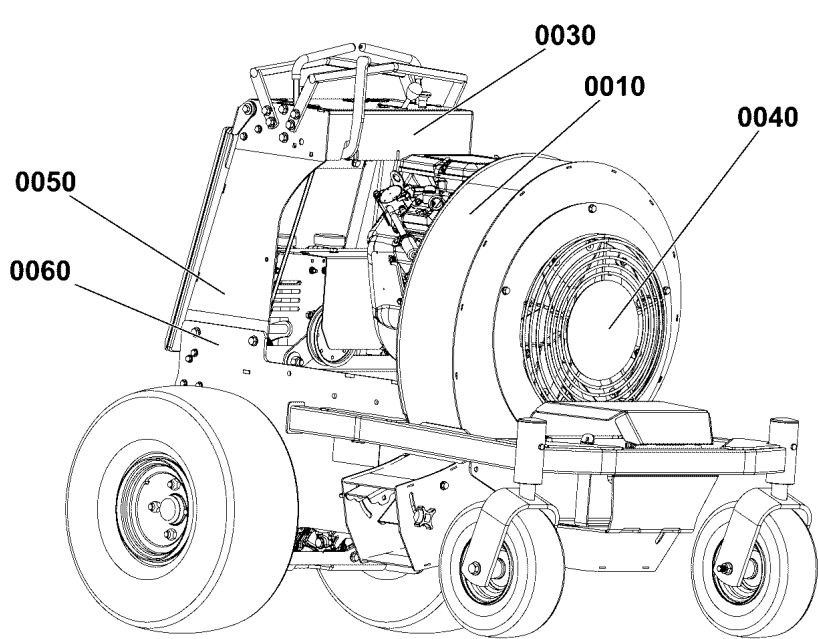

Decal Group - Brand and Model

REF NO	PART NO	QTY	DESCRIPTION
0010	5110342	2	DECAL, P2 HURRICANE VERT
0020	5109615	1	DECAL, P2 CONSOLE
0030	5109614	1	DECAL, P2 BANNER
0040	5110343	1	DECAL, BILLY GOAT LOGO, 7.5
0050	5107557	2	LABEL, PRODUCT DECAL LG CIRCLE
0060	80082701FS	2	DECAL, BRAND

Not For Reproduction

Decal Group - Safety and Operation

Note: Unless noted otherwise, use the standard torque specifications

Mfg. No: 5902011-P2000

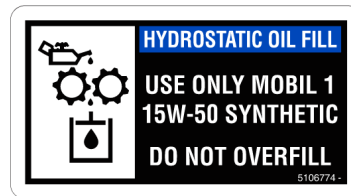
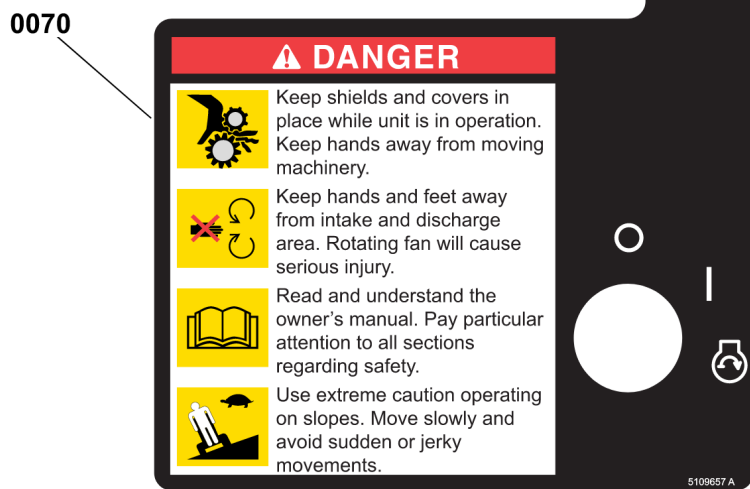
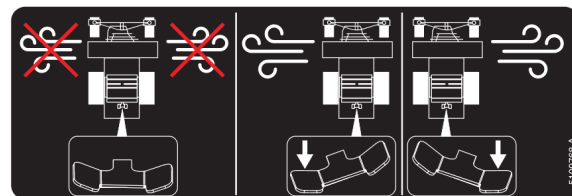
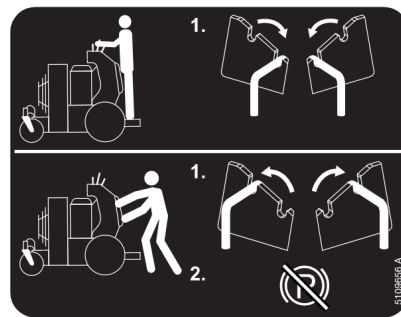
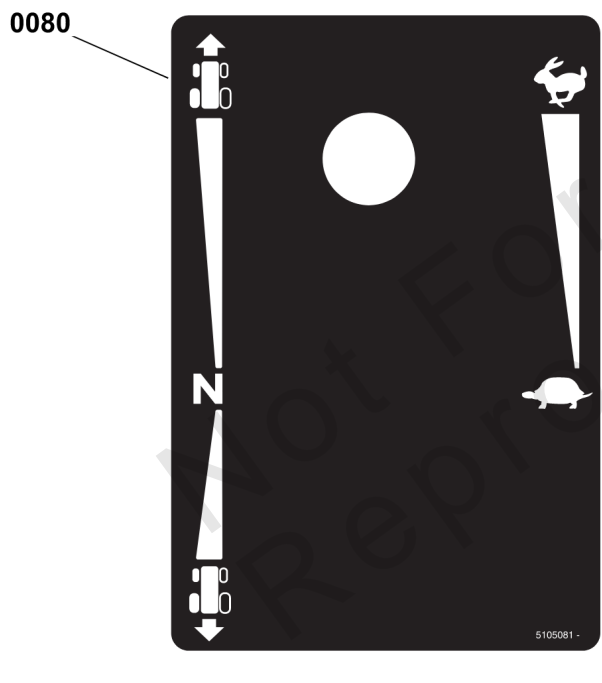
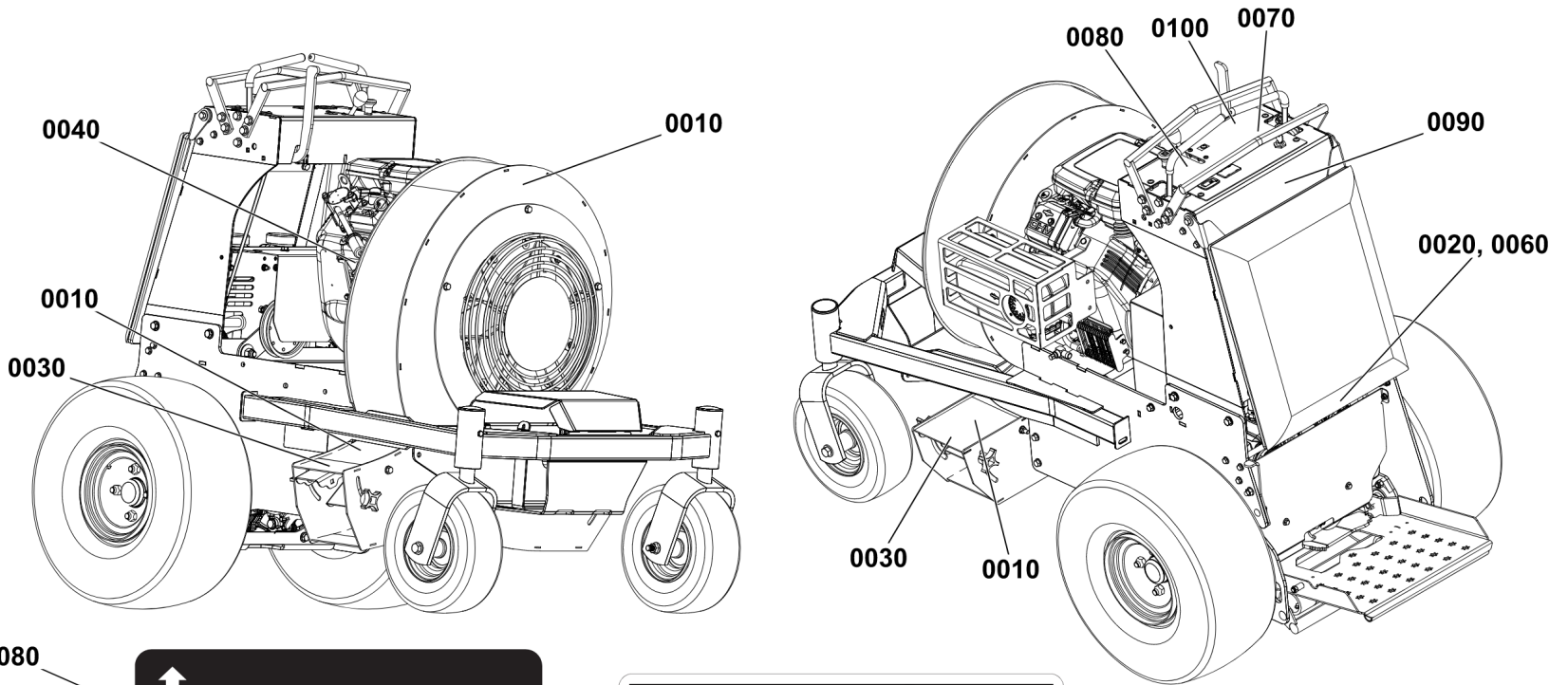

0020

0040

0090

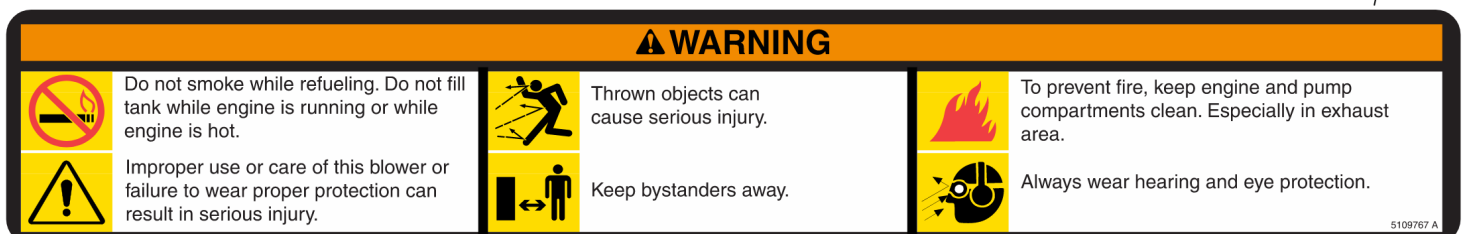

Decal Group - Safety and Operation

REF NO	PART NO	QTY	DESCRIPTION
0010	5106775FS	3	DECAL
0020	5106774FS	1	DECAL -(Located on hydraulic tank mount beneath knee pad.)
0030	5106773FS	2	DECAL, Warning/Safety
0040	5106771FS	1	DECAL, WARNING, HOT SURFACE -(Located on blower housing by engine manifold.)
0060	5109656FS	1	DECAL, INSTRUCTION -(Located on hydraulic tank mount beneath knee pad.)
0070	5109657FS	1	DECAL, CONTROLS
0080	84008405	1	DECAL, Controls
0090	5109767FS	1	DECAL
0100	5109768FS	1	DECAL, Controls

Not For Reproduction

Deflector Control Group

REF NO	PART NO	QTY	DESCRIPTION
0010	5421771AAFS	1	PLATE
0020	5421772AAFS	1	PLATE
0030	5421775AAFS	1	DEFLECTOR
0040	7900009SM	2	RHSSNB, 3/8-16 X 2-1/
0050	5022665SM	2	BODY CLIP, 1/4-20 X 1
0060	5025394SM	11	NUT, 3/8-16 HEX NYLOCK
0070	5042134SM	2	SPACER, .32 X .75 X 1
0080	5021098SM	3	BEARING, BRONZE FLANG
0090	5421674AAFS	1	PLATE
0100	5025145X8SM	4	BOLT, 5/16-18 X 1", C
0110	703867	2	CAPSCREW,5/16-18 X 2
0120	703350	4	WASHER
0130	703115	12	NUT
0140	5025013X10SM	8	BOLT, 3/8-16 X 1-1/4"
0150	84007037	1	BOLT
0160	5025156FS	7	WASHER
0170	5421533AAFS	1	GEAR, SPUR
0180	5100548SM	4	WASHER - .39X1.50
0190	5041930SM	2	SPACER, .38 X .50 X .
0200	5421774AFS	1	PLATE
0210	5421792AAFS	1	PLATE
0220	5421658AAFS	1	ARM, PIVOT
0250	5107740FS	1	SPACER
0260	5107741FS	2	BUSHING
0270	5103262YP	2	SPACER, IDLER ARM
0280	7078243YP	1	BEARING, BALL, AXLE
0290	5025017X12YP	1	BOLT, 1/2-13 X 1-1/2
0300	770225	1	NUT
0310	5010213YP	1	SPRING-EXT, .740 ODX2
0320	5025055X12SM	2	BOLT, 5/16-18 X 1-1/2
0330	5025127SM	2	NUT, 5/16-18 HEX SERR
0340	5421791AAFS	1	DEFLECTOR
0380	5421790AAFS	1	DEFLECTOR
0420	5025011X8FS	2	BOLT
0430	5420561A	1	PLATE, TOE KICK, FB1000 - BLK
0440	703338	2	BOLT,1/4-20X5/8
0450	5025010X6SM	2	BOLT, 1/4-20 X 3/4" G
0460	5025010X8SM	2	BOLT, 1/4-20 X 1", GD
0470	5025391FS	4	NUT
0480	703332	6	WASHER
0500	5109913FS	1	DAMPENER

Electrical Group

Note: Unless noted otherwise, use the standard torque specifications

Mfg. No: 5902011-P2000

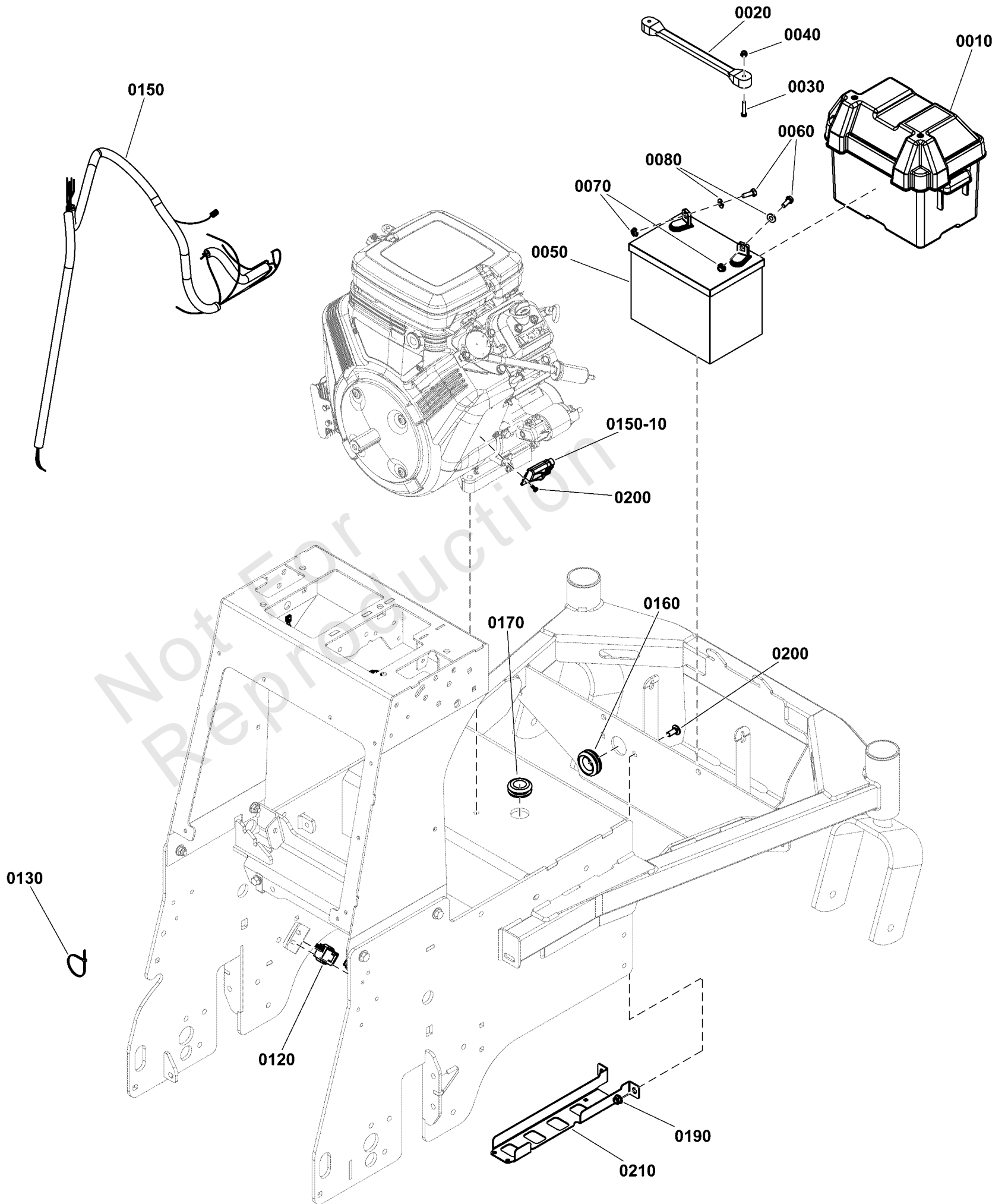

Electrical Group

REF NO	PART NO	QTY	DESCRIPTION
0010	5100688YP	1	BATTERY BOX, W/ DRAIN
0020	5021670SM	1	STRAP, RUBBER
0030	5025270SM	2	SCREW, #10-24 X 1" RS
0040	5025271FS	2	NUT
0050	-----	1	BATTERY, 11U1L, 350 CCA -(BCIU1, 350 CCA)
0060	5025010X6SM	2	BOLT, 1/4-20 X 3/4" G
0070	5025126FS	2	NUT
0080	703332	2	WASHER
0090	5105300FS	1	CABLE, BATTERY, RED
0100	5050927X39FS	1	WIRE, LOOM
0110	5045894YP	1	BATTERY CABLE, NEG, 35, 1/4-5/16
0120	84006599	1	SWITCH
0130	5021030SM	9	TIE WRAP, 5-1/2" LONG
0140	5025470YP	1	SCREW, SELF-TAP, #8-32
0150	5109531FS	1	HARNESS, WIRING
0150-10	5021603SM	1	FUSE, ATO, 20 AMP
0160	5106788FS	1	GROMMET, RUBBER
0170	5103944YP	1	GROMMET, 7/8" ID
0190	703115	2	NUT
0200	703185	2	BOLT, Round Head, Short Square Neck
0210	5421965AFS	1	PLATE

Electrical Schematic

Note: Unless noted otherwise, use the standard torque specifications

Mfg. No: 5902011-P2000

5109531 MAIN WIRE HARNESS - BRIGGS & STRATTON 356447 ENGINES

5109531A

(If internal schematic of the switch is not shown, the image of the switch represents the back view of the connector as it is connected to the switch.)

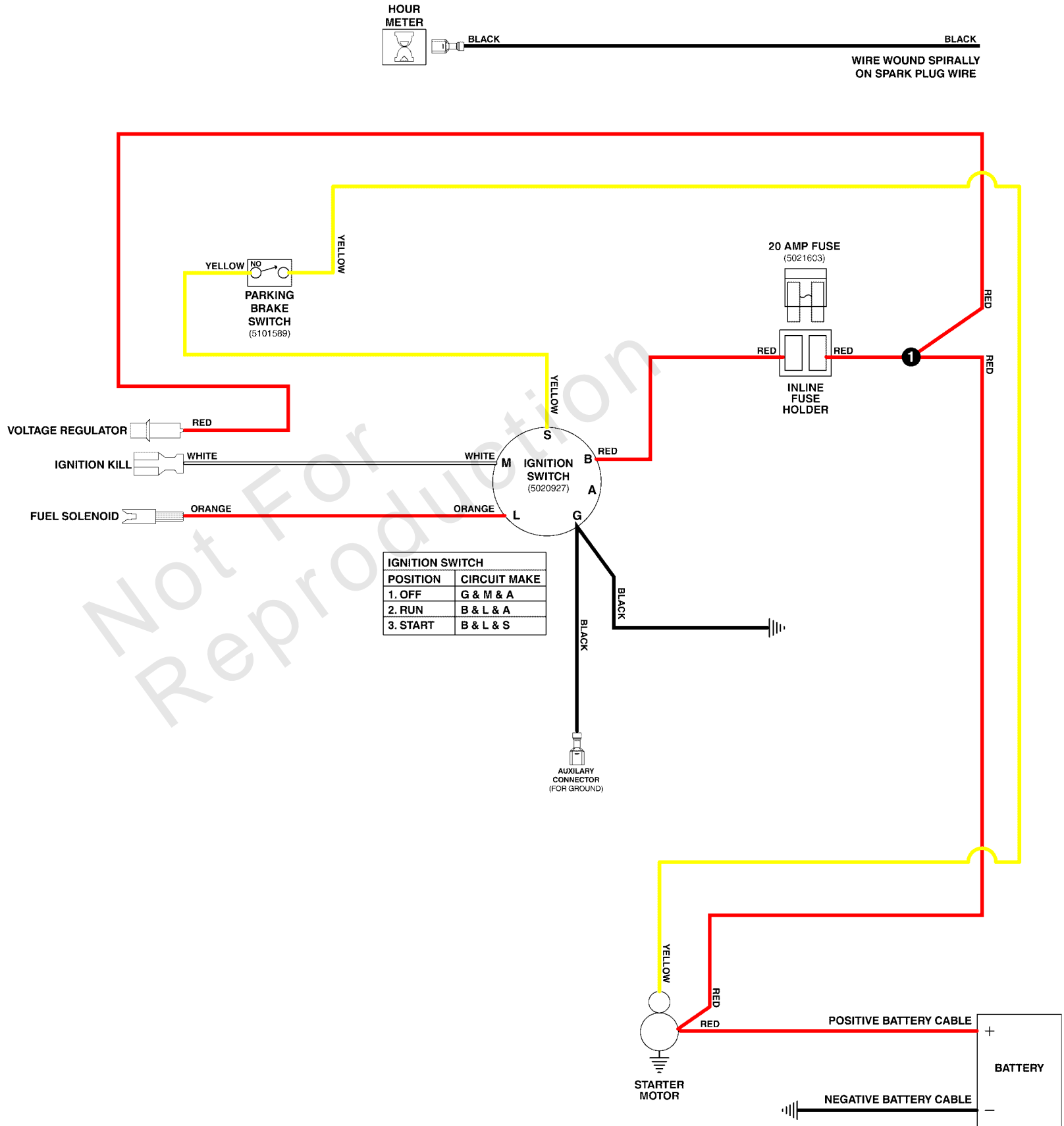

Electrical Schematic

REF NO	PART NO	QTY	DESCRIPTION
5109531	5109531FS	1	HARNESS, WIRING
5021603	5021603SM	1	FUSE, ATO, 20 AMP
5101589	84006599	1	SWITCH
5020927	5020927FS	1	SWITCH, IGNITION

Not For Reproduction

Engine Group

Note: Unless noted otherwise, use the standard torque specifications

Mfg. No: 5902011-P2000

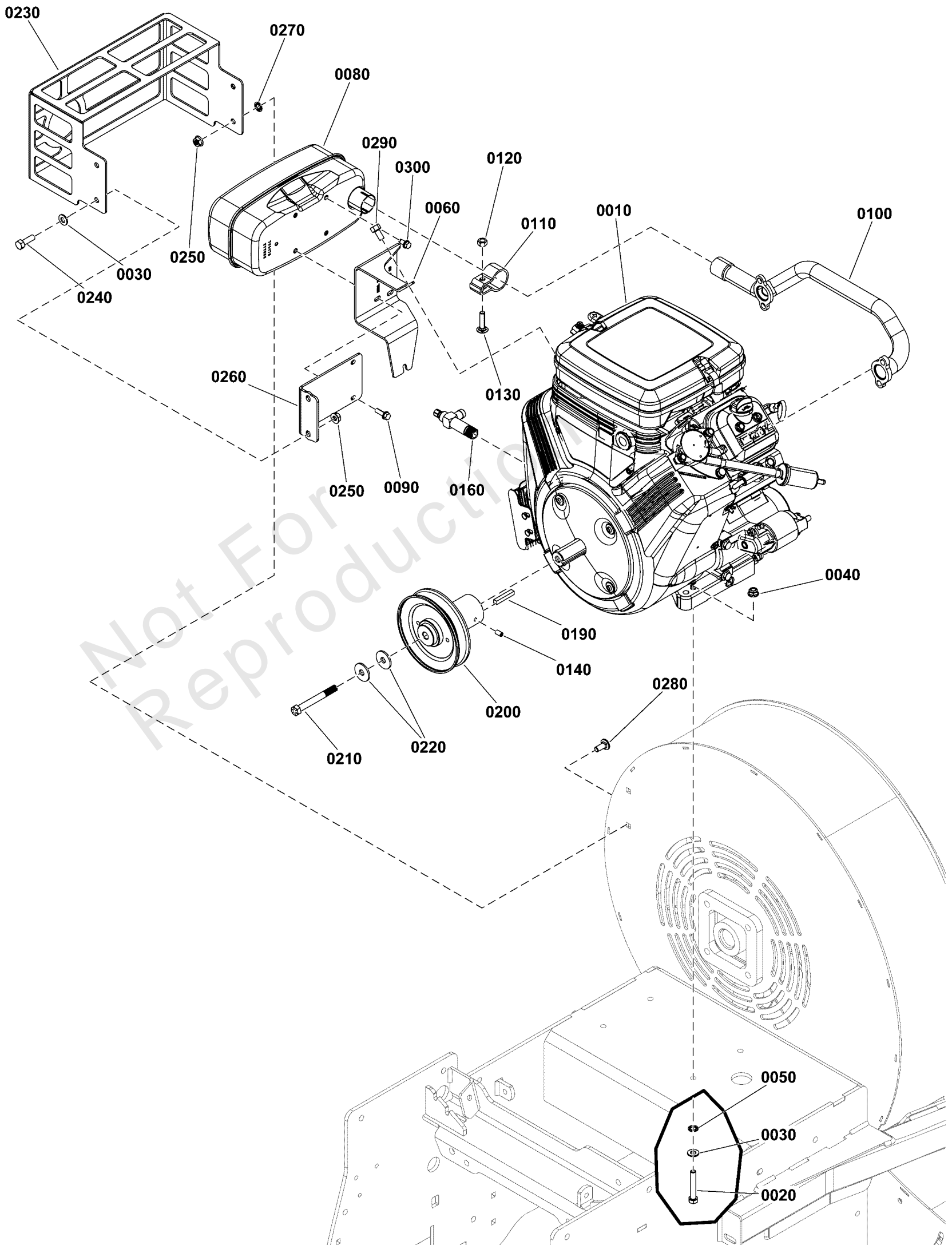

Engine Group

REF NO	PART NO	QTY	DESCRIPTION
0010	-----	1	ENGINE, 356447-3545-G1 -(See engine manufacturer for engine service parts.)
0020	5025025X16	4	BOLT, 5/16-24 x 2" GD 8
0030	703350	6	WASHER
0040	5025616YP	4	NUT
0050	5025188SM	4	WASHER, 5/16" INT. TO
0060	806759	1	BRACKET, Muffler -(Order replacement component from your authorized Briggs & Stratton service parts provider.)
0080	498984S	1	MUFFLER -(Order replacement component from your authorized Briggs & Stratton service parts provider.)
0090	703466	2	BOLT, GR5, 1/4X.0750
0100	805609	1	MANIFOLD, Exhaust -(Order replacement component from your authorized Briggs & Stratton service parts provider.)
0110	691956	1	CLAMP, Muffler -(Order replacement component from your authorized Briggs & Stratton service parts provider.)(Includes items #0120 and 0130.)
0120	691105	1	LOCKNUT
0130	-----	1	BOLT, ROUND HEAD SQUARE NECK
0140	5107269FS	2	SET SCREW
0160	5107284FS	1	VALVE, OIL DRAIN SHUT OFF
0190	5022726YP	1	KEY 1/4 SQ X 1 1/2
0200	5109829FS	1	PULLEY
0210	01X144MA	1	BOLT, 3/8-24 NF x 3-1/4" Hex Head, GR 8
0220	5025693FS	2	WASHER, Beveled
0230	5421920AFS	1	MUFFLER, GUARD
0240	5025011X8FS	2	BOLT
0250	5025127SM	4	NUT, 5/16-18 HEX SERR
0260	5421452AFS	1	GUARD
0270	703297	2	RETAINER, GR5, 5/16
0280	703185	2	BOLT, Round Head, Short Square Neck
0290	703987	1	CAPSCREW, M8-1.25X16
0300	704130	2	SCREW, HEX, 1/4-20X.5

Fuel Tank and Mount Group

Note: Unless noted otherwise, use the standard torque specifications

Mfg. No: 5902011-P2000

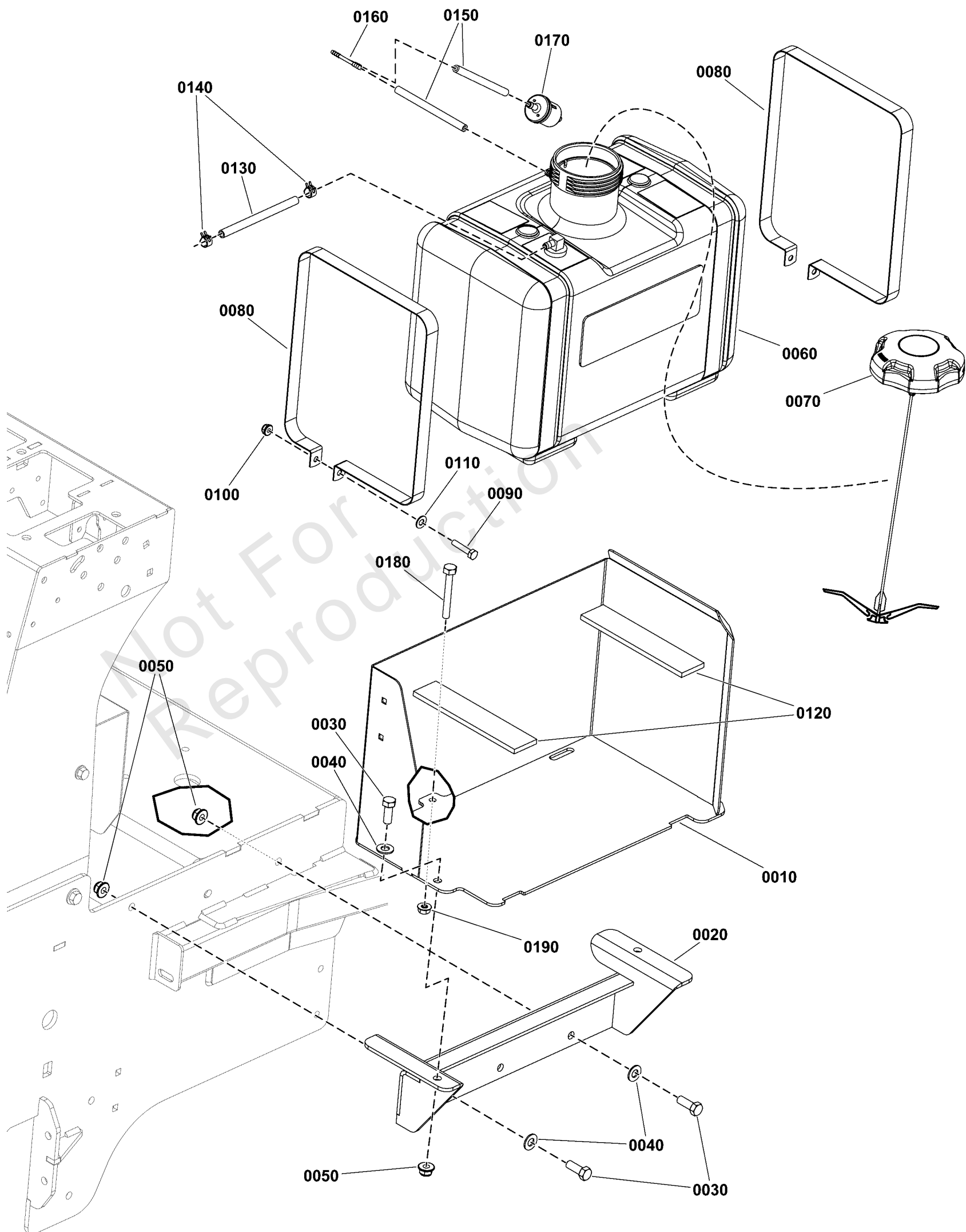

Fuel Tank and Mount Group

REF NO	PART NO	QTY	DESCRIPTION
0010	5420585AFS	1	MOUNT, TANK
0020	5421231A	1	WELD, FUEL TANK MOUNT,LOWER, FB1000-BLK
0030	5025013X8SM	5	BOLT, 3/8-16 X 1" GD5
0040	5025156FS	5	WASHER
0050	5025394SM	5	NUT, 3/8-16 HEX NYLOCK
0060	5102833YP	1	TANK, 5 GAL
0060-10	84009482	1	GROMMET -(Grommet for fuel tank 5102833)
0070	84005958	1	CAP, FUEL TANK
0080	5403445AYP	2	STRAP, FUEL TANK
0090	5025010X12SM	2	BOLT, 1/4-20
0100	5025391FS	2	NUT
0110	703332	2	WASHER
0120	5100810YP	2	PAD, RUBBER MOUNT
0130	5050831X5SM	1	HOSE - 5"
0140	691038	2	CLAMP, Hose
0150	7700552X4P5YP	2	HOSE, VAPOR
0160	5103062YP	1	FITTING, 3/16" TEE, B
0170	84001895	1	FILTER, Fuel
0180	5025055X20FS	1	BOLT
0190	5025127SM	1	NUT, 5/16-18 HEX SERR

Hydraulic Group

Note: Unless noted otherwise, use the standard torque specifications

Mfg. No: 5902011-P2000

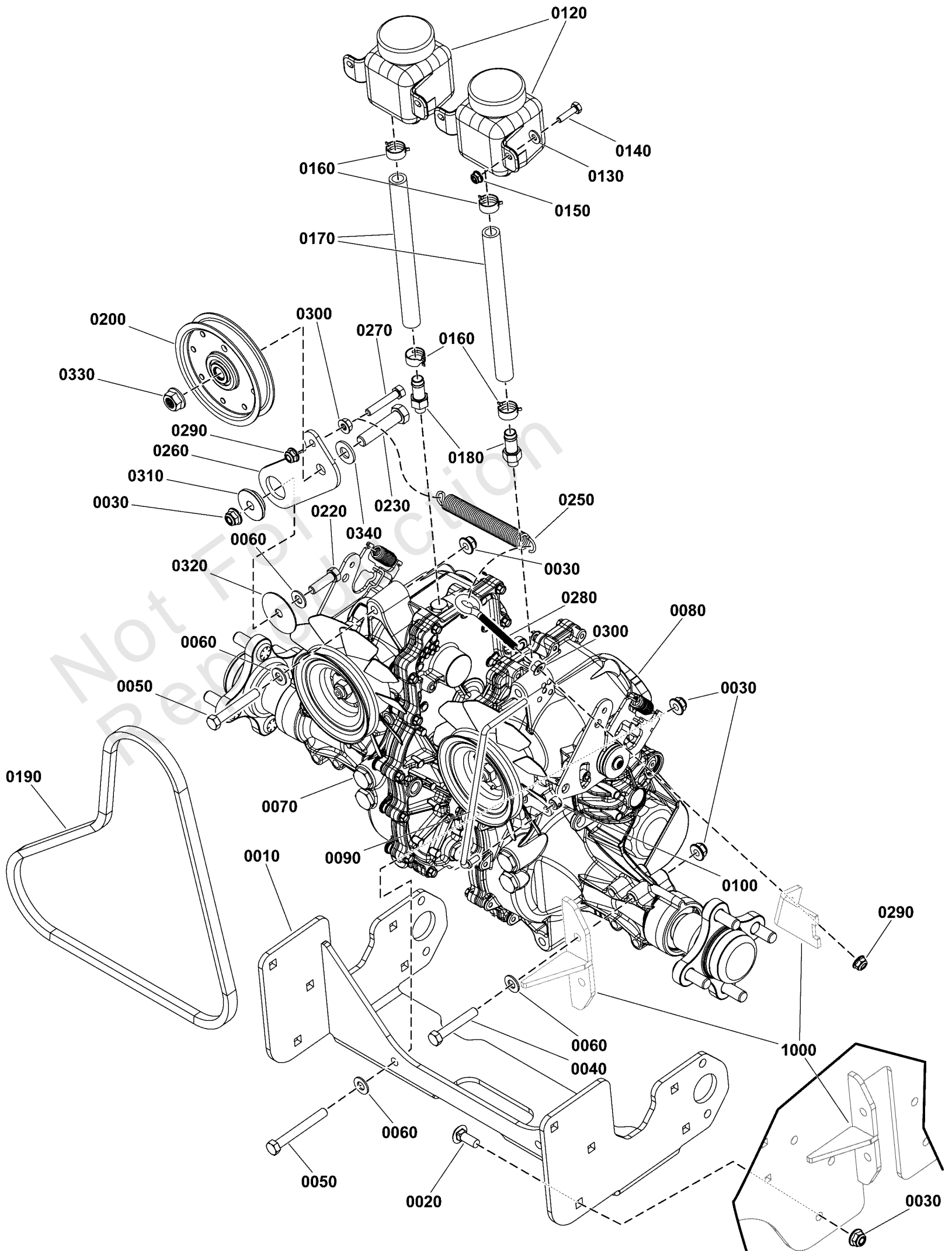

Hydraulic Group

REF NO	PART NO	QTY	DESCRIPTION
0010	5421310AFS	1	SUPPORT, TRANSAXLE
0020	703814	10	BOLT, RD HD, 3/8-16X1
0030	5025394SM	19	NUT, 3/8-16 HEX NYLOCK
0040	5025013X24SM	4	BOLT, 3/8-16 X 3" GD5
0050	84007037	4	BOLT
0060	5025156FS	9	WASHER
0070	84006968	1	TRANSAXLE
0080	84006969	1	TRANSAXLE
0090	5109270FS	2	ROD
0100	5022481SM	2	COLLAR, 1/4" SET
0120	5100473SM	2	RESERVOIR
0120-10	5100778X1YP	2	RESERVIOR CAP (SV) -(Not an illustrated part.)
0130	703332	4	WASHER
0140	5025010X8SM	4	BOLT, 1/4-20 X 1", GD
0150	5025391FS	4	NUT
0160	5025474SM	4	CLAMP - HOSE
0170	5050857X8FS	2	HOSE
0180	5107224FS	2	FITTING
0190	5109484FS	1	BELT
0200	5109471FS	1	PULLEY, IDLER
0220	5025013X10SM	1	BOLT, 3/8-16 X 1-1/4"
0230	5025017X18SM	1	BOLT, 1/2-13
0250	5109476FS	1	SPRING
0260	5421961AAFS	1	PLATE
0270	5025011X14SM	1	BOLT, 5/16-18 X 1-3/4
0280	5025141X26YP	1	EYE BOLT, 5/16-18 X 3
0290	703115	2	NUT
0300	5025127SM	2	NUT, 5/16-18 HEX SERR
0310	706128	1	SPACER, IDLER
0320	5025695	1	WASHER, 0.406 X 2.00 X 0.0465, CZ
0330	770225	1	NUT
0340	5025158SM	1	WASHER, 1/2" SAE
1000	-----	1	Refer to: Main Frame Group

Instrument Control Panel Group

Note: Unless noted otherwise, use the standard torque specifications

Mfg. No: 5902011-P2000

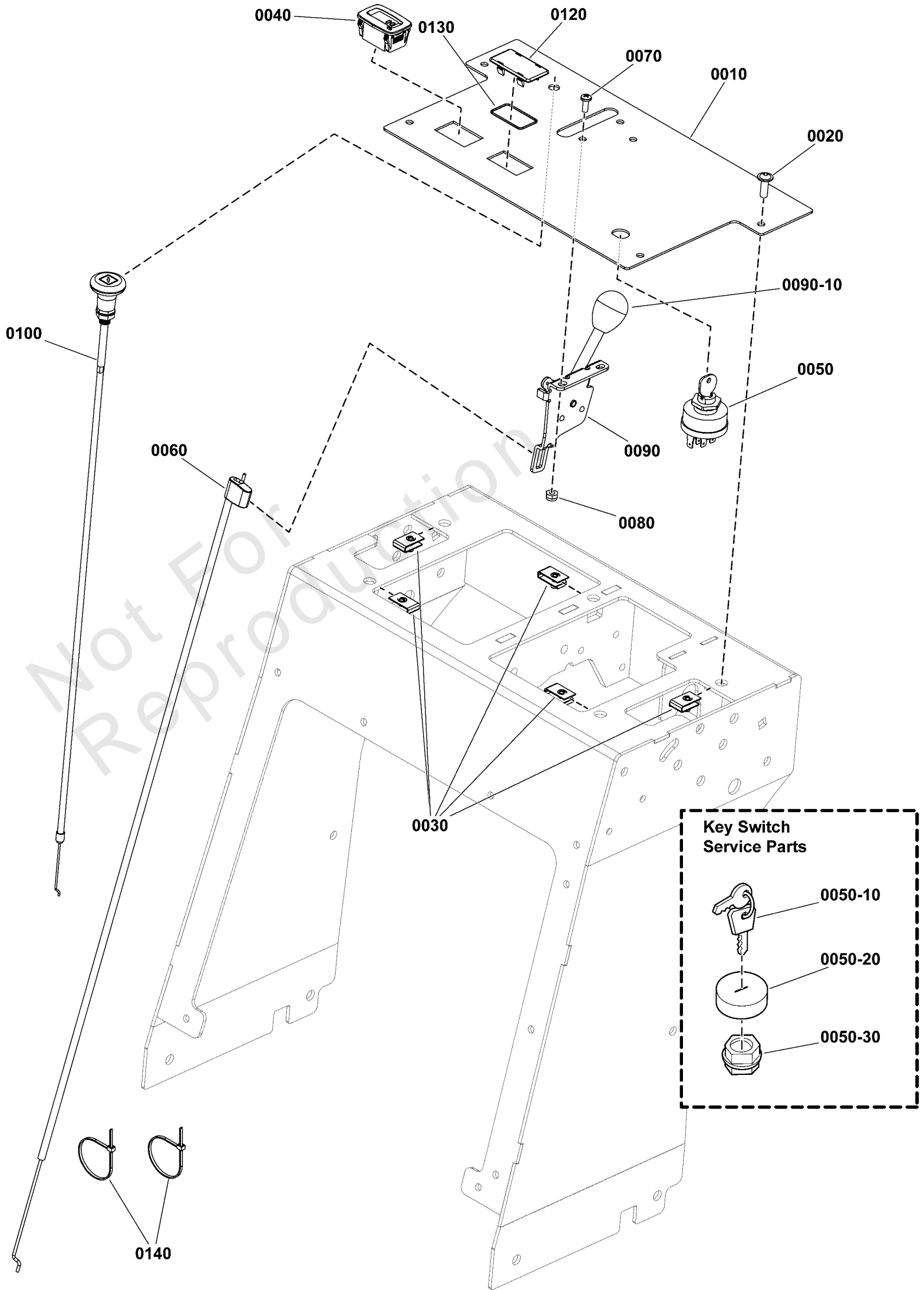

Instrument Control Panel Group

REF NO	PART NO	QTY	DESCRIPTION
0010	5601334	1	DASH PANEL W/ DECALS, P2000 -(Includes decals).
0020	84003668	5	SCREW
0030	5022665SM	5	BODY CLIP, 1/4-20 X 1
0040	5106789FS	1	METER, HOUR
0050	5020927FS	1	SWITCH, IGNITION
0050-10	1717163SM	1	KEY-IGNITION INDAK -(SV)
0050-20	5022790	1	COVER, PLASTIC, SNAP ON -(SV)
0050-30	5022791SM	1	NUT, PLASTIC (SV) -(SV)
0060	5109627FS	1	CABLE, THROTTLE
0070	5025179X4SM	2	SCREW, #10-24 X 1/2" ROUND PHILLIPS
0080	5025271FS	2	NUT
0090	5101995YP	1	LEVER, THROTTLE HD
0090-10	5046360X1SM	1	KNOB, THROTTLE CONTRO
0100	5109628FS	1	CABLE, CONTROL
0120	1722611SM	1	PLUG-HOLE BLACK
0130	5022269SM	1	O-RING, 7/8" ID X 1/1
0140	5021030SM	2	TIE WRAP, 5-1/2" LONG

Main Frame Group

Note: Unless noted otherwise, use the standard torque specifications

Mfg. No: 5902011-P2000

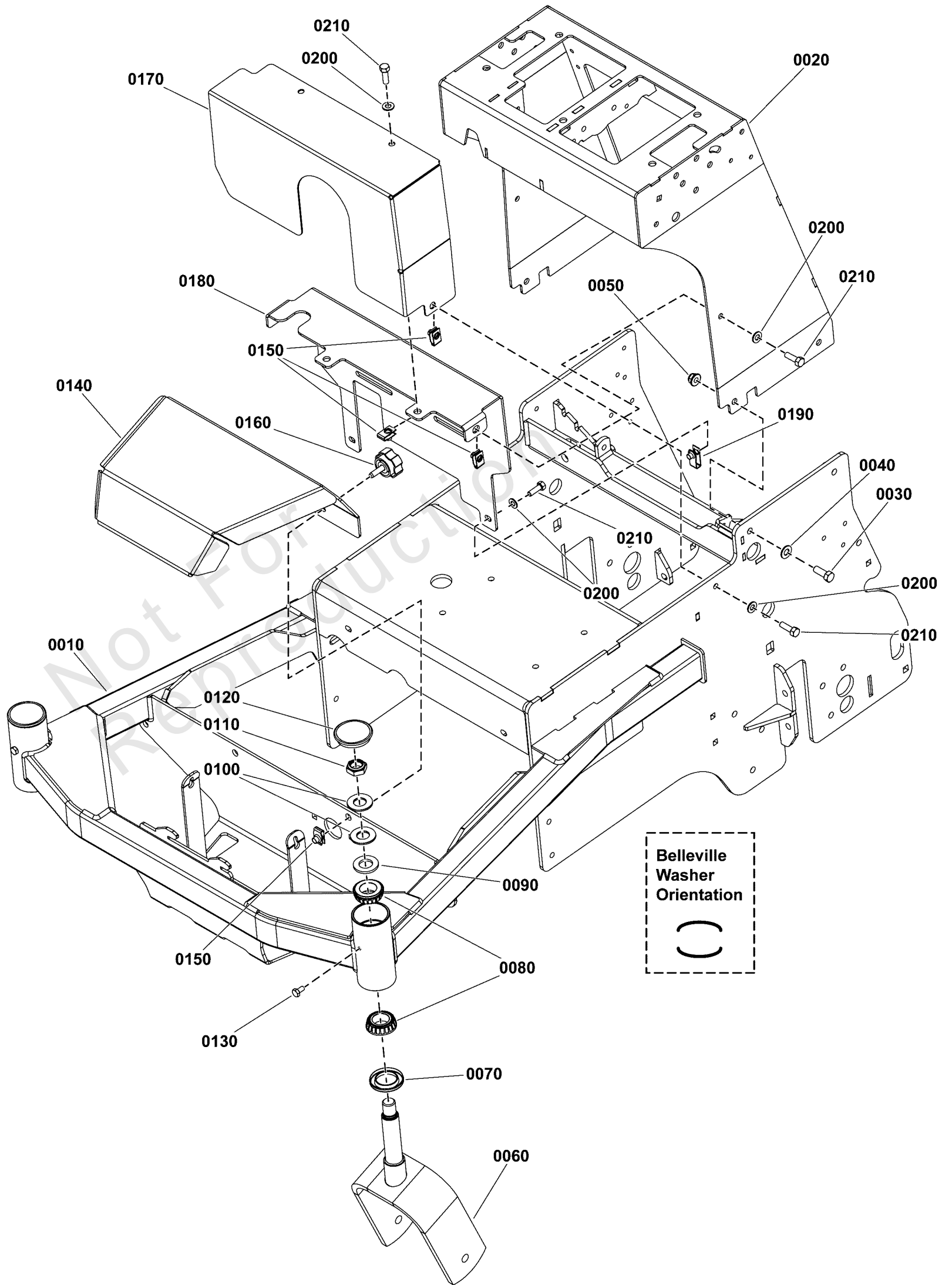

Main Frame Group

REF NO	PART NO	QTY	DESCRIPTION
0010	-----	1	FRAME
0020	5420514AD	1	WELD, CONTROL TOWER, FB1000 - ORG
0030	5025013X8SM	4	BOLT, 3/8-16 X 1" GD5
0040	5025156FS	4	WASHER
0050	5025394SM	4	NUT, 3/8-16 HEX NYLOCK
0060	84008480	2	YOKE, CASTER
0070	5021072SM	2	SEAL, GREASE
0080	5020884SM	4	BEARING, TAPERED ROLL
0090	5025160SM	2	WASHER, 3/4" SAE
0100	5025449SM	4	WASHER, BELLEVILLE
0110	5025448SM	2	NUT - 3/4-16 HEX JAM
0120	5109845FS	2	CAP
0130	5025457SM	2	BOLT - 1/4-28 X 1/2
0140	5421743A	1	PLATE, BATTERY MOUNT COVER, FB1000 - BLK
0150	5022308SM	7	BODY CLIP, 5/16-18 X
0160	5108141FS	2	KNOB
0170	5420565AD	1	PLATE, BELT GUARD, FB1000 - ORG
0180	5421529AAFS	1	MOUNT, TANK
0190	5025452YP	2	CLIP
0200	703350	7	WASHER
0210	5025011X8FS	7	BOLT

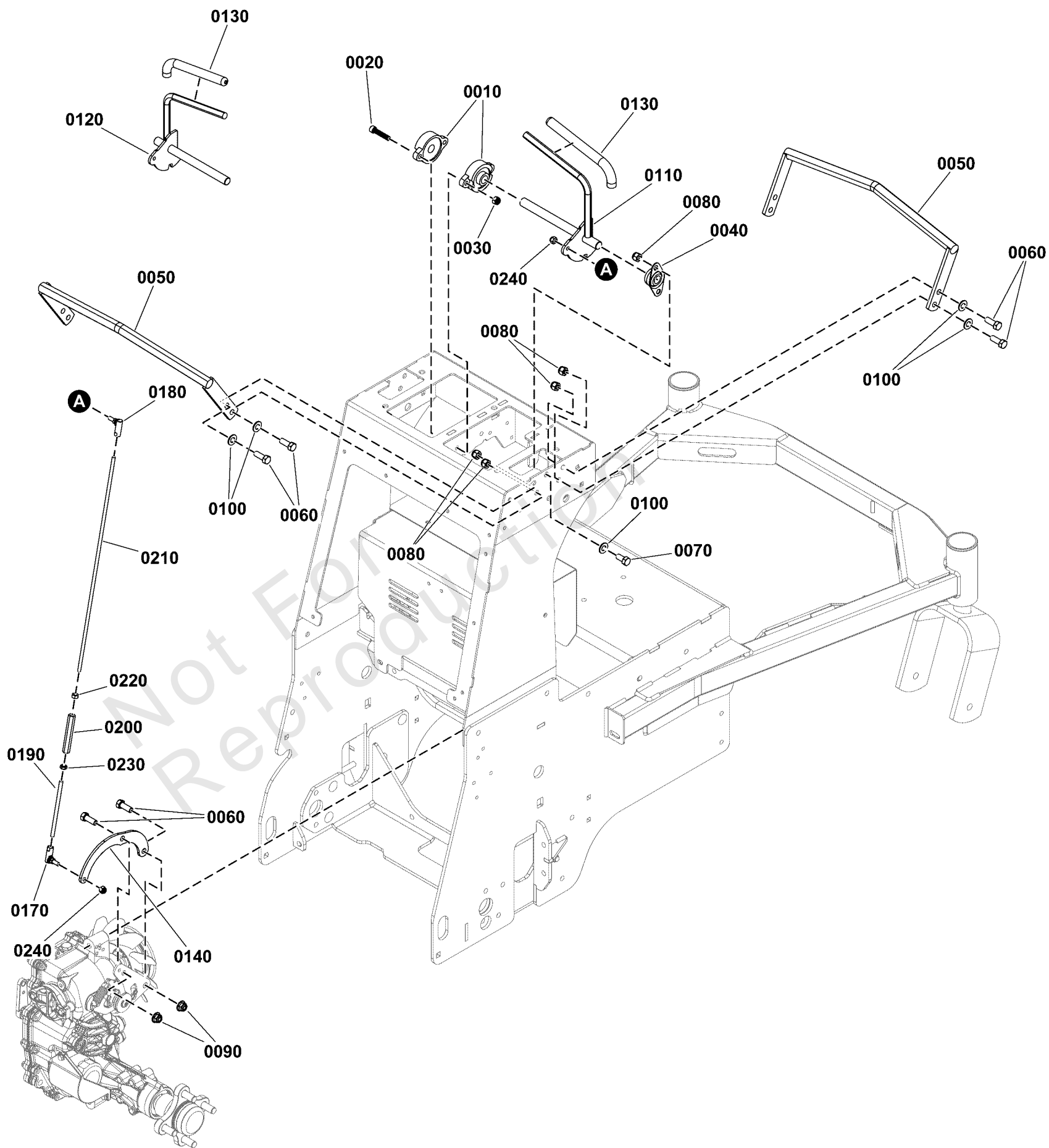

Motion Control Group

REF NO	PART NO	QTY	DESCRIPTION
0010	5022846SM	2	BEARING, FLANGE, 5/8
0020	5025618X12FS	2	SCREW
0030	5025057FS	2	NUT
0040	5104885FS	2	BEARING
0050	5414243AAFS	2	HANDLE, REAR
0060	5025013X8SM	12	BOLT, 3/8-16 X 1" GD5
0070	5025013X6SM	4	BOLT, 3/8-16 X 3/4" G
0080	5025096SM	12	NUT, 3/8-16 HEX NYLON
0090	5025394SM	4	NUT, 3/8-16 HEX NYLOCK
0100	5025156FS	12	WASHER
0110	5420574AAFS	1	CONTROL, HANDLE
0120	5420575AAFS	1	CONTROL, HANDLE
0130	5100619FS	2	GRIP
0140	5421889AAFS	2	ARM, CONTROL
0170	5106802FS	2	JOINT, BALL
0180	5106803FS	2	JOINT, BALL
0190	5107303FS	2	ROD
0200	5106971FS	2	TUBE, CONNECTING
0210	5107239FS	2	ROD, LINK
0220	5106858FS	2	NUT
0230	7090095FS	2	NUT, 1/4
0240	5106892FS	4	NUT

Neutral Lock Group

Note: Unless noted otherwise, use the standard torque specifications

Mfg. No: 5902011-P2000

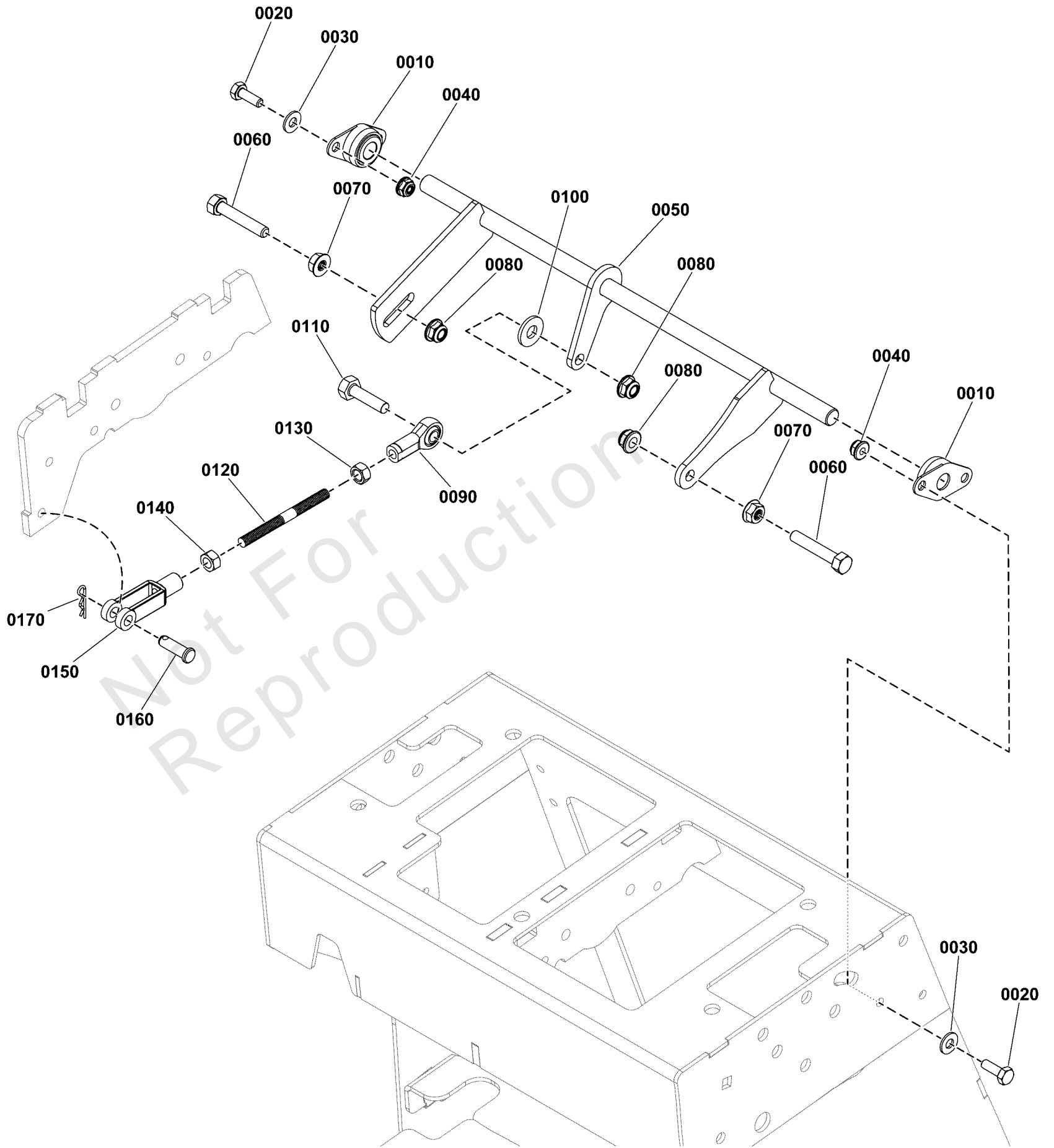

Neutral Lock Group

REF NO	PART NO	QTY	DESCRIPTION
0010	5101123SM	2	BEARING, 1/2 FLANGE
0020	5025010X6SM	4	BOLT, 1/4-20 X 3/4" G
0030	84007033	4	WASHER
0040	5025391FS	4	NUT
0050	5420577AAFS	1	LOCK, Neutral
0060	5025011X14SM	2	BOLT, 5/16-18 X 1-3/4
0070	5025127SM	2	NUT, 5/16-18 HEX SERR
0080	703115	3	NUT
0090	5104494YP	1	BALL JOINT 5/16-24 LH
0100	5025337FS	1	WASHER
0110	5025055X10YP	1	BOLT, 5/16-18 X 1-1/4
0120	5104695FS	1	ROD
0130	5023212SM	1	NUT, 5/16-24 HEX, LH
0140	5025033FS	1	NUT
0150	5023323SM	1	CLEVIS, 5/16-24, STEE
0160	5025213X8SM	1	PIN, CLEVIS, 5/16" X
0170	5025211SM	1	PIN, HAIR, .0585" X 1

Operator Area Group

Note: Unless noted otherwise, use the standard torque specifications

Mfg. No: 5902011-P2000

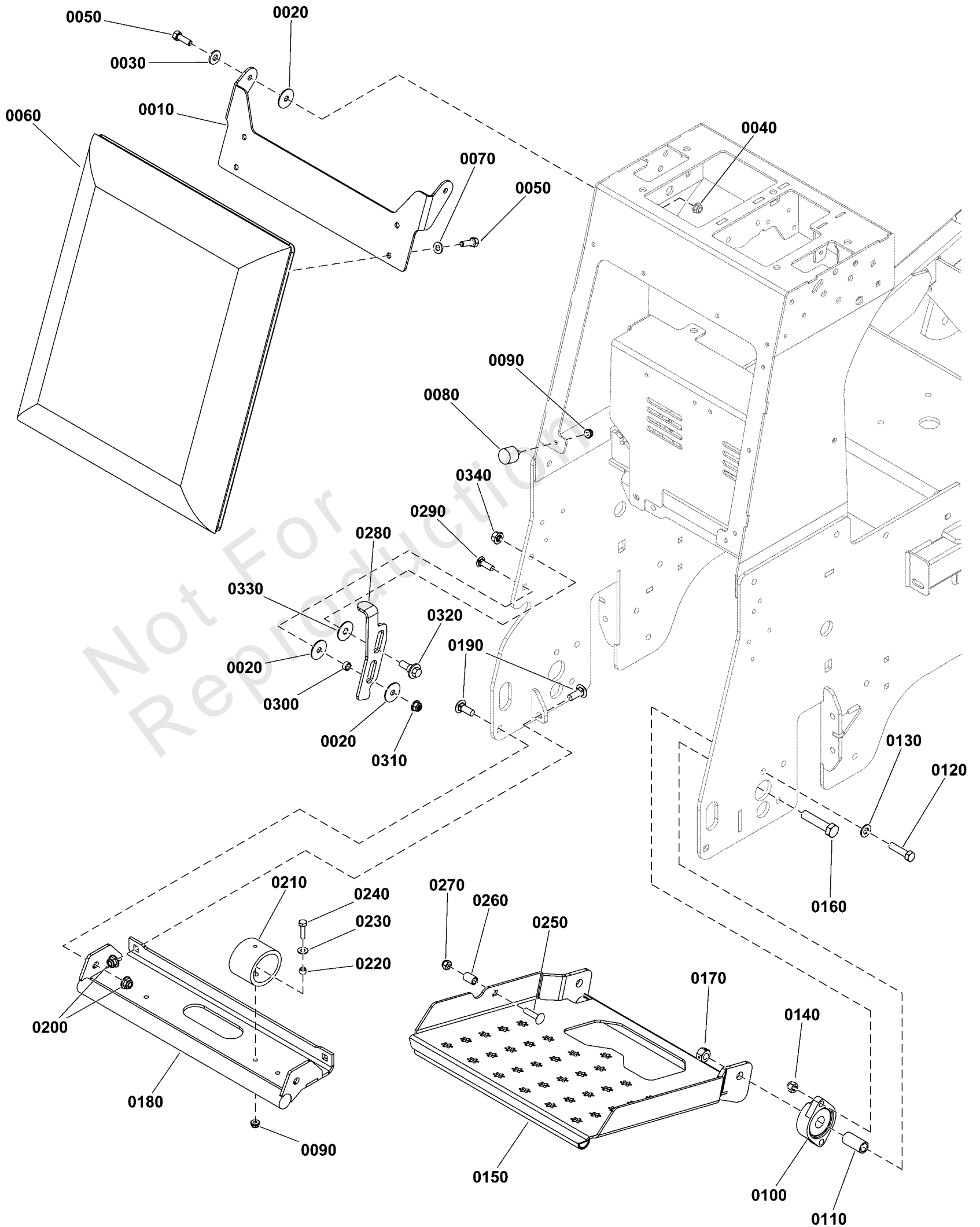

Operator Area Group

REF NO	PART NO	QTY	DESCRIPTION
0010	5415658A	1	PLATE, PAD MOUNT, SRSZ1 - BLK
0020	5025164SM	4	WASHER, 5/16" FENDER
0030	5025337FS	2	WASHER
0040	703115	2	NUT
0050	5025011X8FS	6	BOLT
0060	5109578FS	1	PAD, KNEE
0070	703350	4	WASHER
0080	5022673SM	2	BUMPER, RUBBER 1/4-20
0090	5025391FS	6	NUT
0100	5021499SM	2	BEARING, FLANGE
0110	5104658FS	2	SPACER
0120	5025013X12SM	4	BOLT, 3/8-16 X 1-1/2"
0130	5025156FS	4	WASHER
0140	5025096SM	4	NUT, 3/8-16 HEX NYLON
0150	5421234AFS	1	PLATFORM
0160	5025017X18SM	2	BOLT, 1/2-13
0170	5025332SM	2	NUT - SIDE LOCK
0180	5421242AFS	1	MOUNT
0190	703814	4	BOLT, RD HD, 3/8-16X1
0200	5025394SM	4	NUT, 3/8-16 HEX NYLOCK
0210	5105128FS	4	BUMPER
0220	5021878YP	4	SPACER, .25 X .37
0230	84007033	4	WASHER
0240	5025010X8SM	4	BOLT, 1/4-20 X 1", GD
0250	703446	1	BOLT, 5/16-18X1.25 G5
0260	5101352FS	1	SPACER
0270	5025057FS	1	NUT
0280	5421299AFS	1	PLATE
0290	5025145X8SM	1	BOLT, 5/16-18 X 1", C
0300	5102463YP	1	SPACER, .33 X .50X.25
0310	704067	1	NUT, HEX FLNG,5/16-18
0320	009X51MA	1	BOLT-SHD.38-16X.499D
0330	5025165SM	1	WASHER, 3/8" FENDER
0340	5025666FS	1	NUT

Parking Brake Group

Note: Unless noted otherwise, use the standard torque specifications

Mfg. No: 5902011-P2000

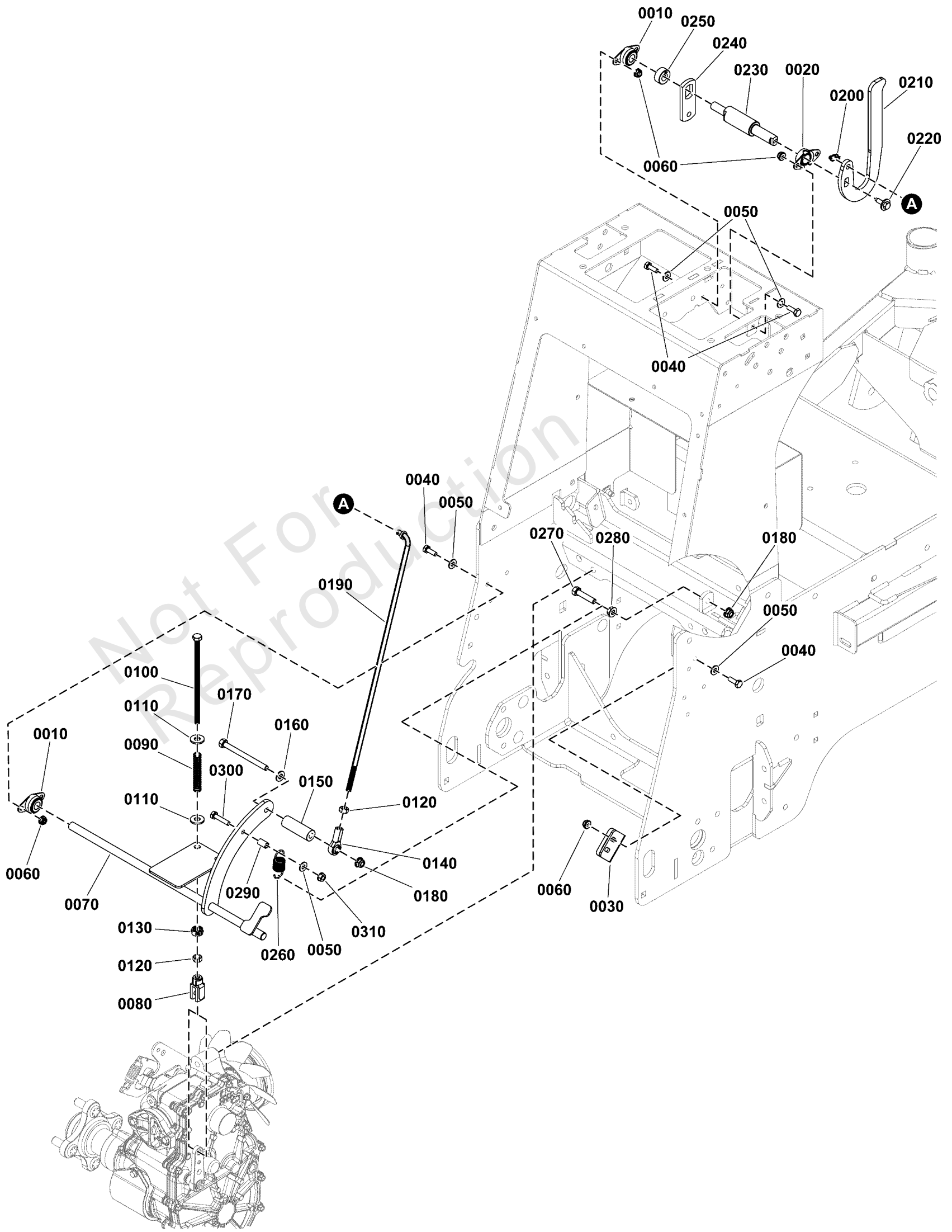

Parking Brake Group

REF NO	PART NO	QTY	DESCRIPTION
0010	5101123SM	3	BEARING, 1/2 FLANGE
0020	5104270YP	1	BEARING-FLANGE
0030	5415132AAFS	1	PLATE, SWITCH
0040	5025010X6SM	10	BOLT, 1/4-20 X 3/4" G
0050	84007033	11	WASHER
0060	5025391FS	10	NUT
0070	5420562AAFS	1	PIVOT
0080	5025688	2	CLEVIS, 5/16-24, STEEL,W/PIN, CZ
0090	5020637YP	2	SPRING-COMP, .375IDX2
0100	5025012X52	2	BOLT, 5/16-24 X 6.50, GD8, CZ
0110	5025337FS	4	WASHER
0120	5025033FS	3	NUT
0130	5102997FS	2	COLLAR
0140	5104493YP	1	BALL JOINT 5/16-24 RH
0150	5109600FS	1	SPACER
0160	703350	1	WASHER
0170	5025011X30SM	1	BOLT, 5/16-18 X 3-3/4 GD5
0180	703115	2	NUT
0190	5109524FS	1	ROD, BRAKE
0200	5025639FS	1	PIN, RETAINER
0210	5421092AAFS	1	PLATE
0220	2860664SM	1	SCREW, HEX SEMS WSHR,
0230	5104953FS	1	SHAFT, BRAKE
0240	5106314FS	1	PLATE
0250	5010580FS	1	COLLAR
0260	5010213YP	1	SPRING-EXT, .740 ODX2
0270	5025055X12SM	1	BOLT, 5/16-18 X 1-1/2
0280	5025127SM	1	NUT, 5/16-18 HEX SERR
0290	5041483YP	1	SPACER
0300	5025010X10SM	1	BOLT, 1/4-20 X 1-1/4"
0310	15X143MA	1	NUT,25-20 HEX FLG CTR

Wheel and Tire Group

Note: Unless noted otherwise, use the standard torque specifications

Mfg. No: 5902011-P2000

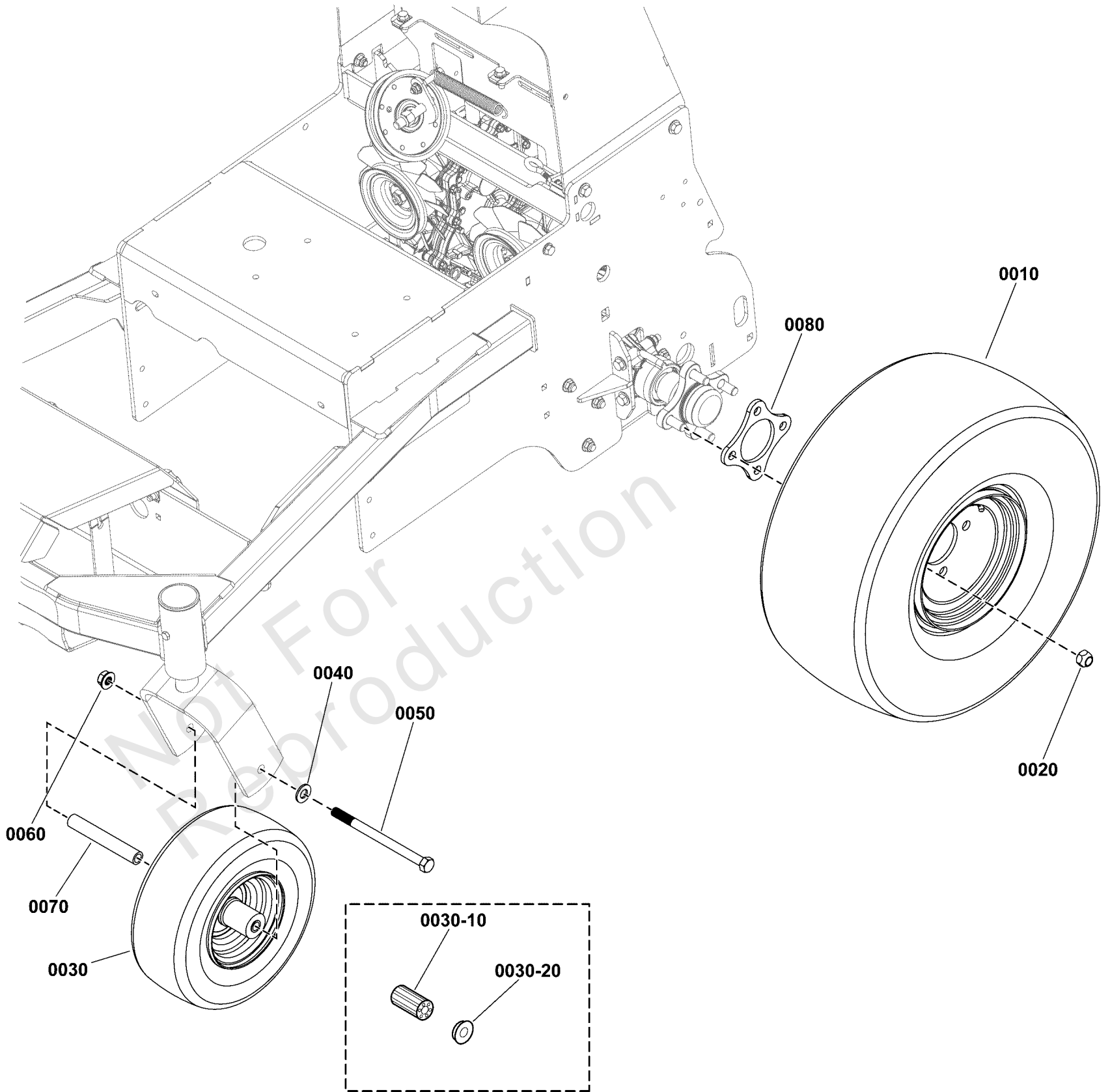

Wheel and Tire Group

REF NO	PART NO	QTY	DESCRIPTION
0010	5109292FS	2	TIRE ASSEMBLY
0020	5020601SM	8	NUT, 1/2-20, FOR WHEEL BOLT SILVER
0030	5100715YP	2	TIRE ASSM
0030-10	5101418X1YP	4	BEARING, CASTER WHEEL, 11 X 4.0 - 5 BEAD LOCK (SV) -(2 per tire)
0030-20	5021043SM	4	RETAINER, Bearing -(2 per tire)
0040	5025158SM	2	WASHER, 1/2" SAE
0050	5025017X56YP	2	BOLT, 1/2-13 X 7 GD5
0060	770225	2	NUT
0070	5045996SM	2	CASTER AXLE DDSH
0080	5403335AAFS	2	PLATE, SPACER

Not For Reproduction

Hardware Identification & Torque Specifications

Torque Specification Chart								
FOR STANDARD METRIC MACHINE HARDWARE (Tolerance ± 20%)								
Property Class	5.6		8.8		10.9		12.9	
	Class 5.6		Class 8.8		Class 10.9		Class 12.9	
Size Of Hardware	in/lbs	Nm.	in/lbs	Nm.	in/lbs	Nm.	in/lbs	Nm.
	ft/lbs		ft/lbs		ft/lbs		ft/lbs	
M3	5.88	.56	13.44	1.28	19.2	1.80	22.92	2.15
M4	13.44	1.28	30.72	2.90	43.44	4.10	52.56	4.95
M5	26.4	2.50	60.96	5.75	5.97	8.10	7.15	9.7
M6	44.64	4.3	7.3	9.9	10.3	14	12.1	16.5
M7	5.2	7.1	12.1	16.5	16.9	23	19.9	27
M8	7.7	10.5	17.7	24	25	34	29	40
M10	15	21	35	48	50	67	59	81
M12	26	36	61	83	86.2	117	103	140
M14	42	58	101	132	136	185	162	220
M16	64	88	147	200	210	285	250	340
M18	89	121	202	275	287	390	346	470
M20	126	171	290	390	405	550	486	660
M22	169	230	390	530	559	745	656	890
M24	217	295	497	375	708	960	840	1140
M27	320	435	733	995	1032	1400	1239	1680
M30	435	590	995	1350	1401	1900	1681	2280
M33	590	800	1349	1830	1902	2580	2278	3090
M36	759	1030	1740	2360	2441	3310	2935	3980
M39	988	1340	2249	3050	3163	4290	3798	5150

Torque Specification Chart						
FOR STANDARD MACHINE HARDWARE (Tolerance ± 20%)						
Hardware Grade	No Marks		SAE Grade 5		SAE Grade 8	
	SAE Grade 2		SAE Grade 5		SAE Grade 8	
Size Of Hardware	in/lbs	Nm.	in/lbs	Nm.	in/lbs	Nm.
	ft/lbs		ft/lbs		ft/lbs	
8-32	19	2.1	30	3.4	41	4.6
8-36	20	2.3	31	3.5	43	4.9
10-24	27	3.1	43	4.9	60	6.8
10-32	31	3.5	49	5.5	68	7.7
1/4-20	66	7.6	8	10.9	12	16.3
1/4-28	76	8.6	10	13.6	14	19.0
5/16-18	11	15.0	17	23.1	25	34.0
5/16-24	12	16.3	19	25.8	29	34.0
3/8-16	20	27.2	30	40.8	45	61.2
3/8-24	23	31.3	35	47.6	50	68.0
7/16-14	30	40.8	50	68.0	70	95.2
7/16-20	35	47.6	55	74.8	80	108.8
1/2-13	50	68.0	75	102.0	110	149.6
1/2-20	55	74.8	90	122.4	120	163.2
9/16-12	65	88.4	110	149.6	150	204.0
9/16-18	75	102.0	120	163.2	170	231.2
5/8-11	90	122.4	150	204.0	220	299.2
5/8-18	100	136	180	244.8	240	326.4
3/4-10	160	217.6	260	353.6	386	525.0
3/4-16	180	244.8	300	408.0	420	571.2
7/8-9	140	190.4	400	544.0	600	816.0
7/8-14	155	210.8	440	598.4	660	897.6
1-8	220	299.2	580	788.8	900	1,244.0
1-12	240	326.4	640	870.4	1,000	1,360.0

The guides and ruler furnished below are designed to help you select the appropriate hardware.

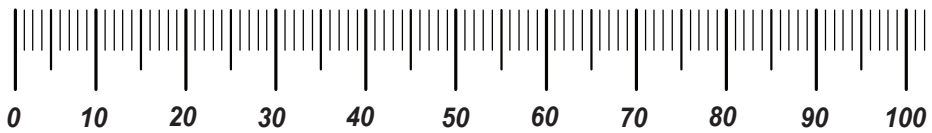

Nut, M8

Thread Diameter (mm)

Inside Diameter (in) Threads per inch

Nut, 1/2-16



Screw, M8- 1.25 x 25

Thread Diameter (mm) Distance between threads (mm) Body Length (mm)

Body Diameter Threads per inch Body Length (in)

Screw, 1/2- 16 x 2



Standard Hardware Sizing

When a washer or nut is identified as 1/2" (M8), this is the *Nominal size*, meaning the *inside diameter* is 1/2 inch (8mm metric thread diameter); if a second number is present it represents the *threads per inch* (distance between threads).

When bolt or capscrew is identified as 1/2 - 16 x 2" (M8 - 1.25 x 50), this means the *Nominal size*, or body diameter is 1/2 inch (8mm metric thread diameter), the second number, 16, represents the *threads per inch*, (*distance between threads*). The final number is the body length of the bolt or screw, 2 inches (50mm).

NOTES

- These torque values are to be used for all hardware excluding: locknuts, self-tapping screws, thread forming screws, sheet metal screws and socket head setscrews.
- Recommended seating torque values for locknuts:
 - for prevailing torque locknuts - use 65% of grade 5 torques.
 - for flange whizlock nuts and screws - use 135% of grade 5 torques.
- Unless otherwise noted on assembly drawings, all torque values must meet this specification.

Common Hardware Types

Hex Head Capscrew

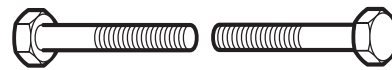

Washer



Carriage Bolt

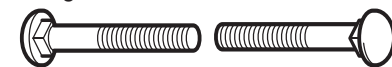

Hex Nut

Wrench & Fastener Size Guide

1/4" Bolt or Nut Wrench—7/16"	5/16" Bolt or Nut Wrench—1/2"	3/8" Bolt or Nut Wrench—9/16"	7/16" Bolt or Nut Wrench (Bolt)—5/8" Wrench (Nut)—11/16"	1/2" Bolt or Nut Wrench—3/4"
M6 Bolt or Nut Wrench—10mm	M8 Bolt or Nut Wrench—13mm	M10 Bolt or Nut Wrench—17mm	M12 Bolt or Nut Wrench—19mm	M14 Bolt or Nut Wrench—22mm

